

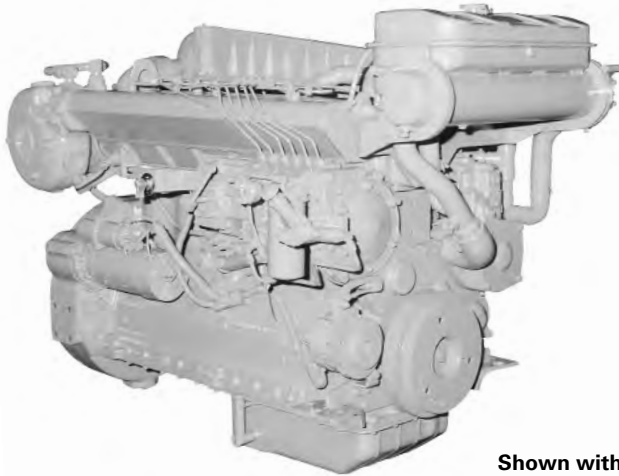

Marine Propulsion Engine 3306B

160 bkW (215 bhp) 218 mhp @ 2000 rpm



Shown with Accessory Equipment

SPECIFICATIONS

I-6, 4-Stroke-Cycle-Diesel

Emissions	IMO compliant
Displacement	10.5 L (641 cu. in.)
Bore	121 mm (4.8 in.)
Stroke	152 mm (6.0 in.)
Aspiration	Turbocharged-Aftercooled
Governor	Hydra-mechanical
Engine Weight, Net Dry (approx)	1120.9 kg (2469 lb)
Capacity for Liquids	
Cooling System	18.2 L (4.8 U.S. gal)
Lube Oil System (refill)	27.4 L (7.2 U.S. gal)
Oil Change Interval	250 hr
Caterpillar DEO	10W30 or 15W40
Rotation (from flywheel end)	Counterclockwise

STANDARD EQUIPMENT

Air Inlet System

Dry, regular duty air cleaner

Cooling System

Gear driven centrifugal jacket water pump, engine oil cooler, expansion tank, thermostats and housing, transmission oil cooler

Exhaust System

Watercooled manifold and turbocharger; dry elbow and flange, 152 mm (6 in.)

Flywheel and Flywheel Housing

SAE No. 1 (156 teeth)

Fuel System

Fuel priming pump, fuel transfer pump, fuel filter, flexible fuel lines

Instruments

Fuel pressure gauge, service meter, heavy-duty standard SAE rotation tachometer drive

Lube System

Top-mounted crankcase breather, oil filter, LH oil filler and oil level gauge, oil pan

Mounting System

Front support

General

Vibration damper and guard, Caterpillar yellow paint, lifting eyes

ACCESSORY EQUIPMENT

Air Cleaner Rain Cap

Air Starting Motor

12V 51 Amp, 24V 35 Amp, 24V 60 Amp Alternator

Auxiliary Drive Pulley

Digital Tachometer

Double Wall Fuel Lines and Drain

Duplex Fuel Filter

Electric Overspeed Shutoff

Electric Starting Motor

Engine-Mounted Instrument Panel

Ether Starting Air

Exhaust Elbow, Pipe, Rain Cap, Flexible Fittings

Front Enclosed Clutch

Fuel Ratio Control

Hydraulic Pump Drive

Magnetic Pickup

Manual Shutoff Lever

Manual Sump Pump

Pilot House Instrument Panel

Primary Fuel Filter/Water Separator

Remote-Mounted Pilot House Controls

Remote Positive Locking Governor Control

RH Oil Level Gauge

Shutoff Solenoid — ETR

Spare Parts Kit

PERFORMANCE CURVES

A Rating — DM6061-00

IMO Compliant

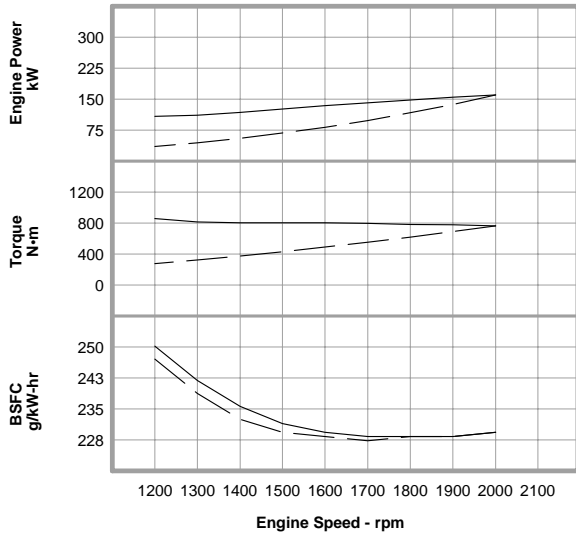

Metric **Maximum Power** ——— **160 kW**
Prop Demand - - - - -

Performance Data

	Engine Speed rpm	Engine Power kW	Engine Torque N·m	BSFC g/kW-hr	Fuel Rate L/hr
Maximum Power Data	2000	160	764	230.0	43.9
	1900	155	777	229.0	42.1
	1800	148	783	229.0	40.2
	1700	141	794	229.0	38.6
	1600	134	802	230.0	36.9
	1500	126	802	232.0	34.9
	1400	118	802	236.0	33.0
	1300	111	815	242.0	32.0
1200	108	859	250.0	32.2	
Prop Demand Data	2000	160	764	230.0	43.9
	1900	137	689	229.0	37.5
	1800	117	619	229.0	31.8
	1700	98	552	228.0	26.8
	1600	82	489	229.0	22.3
	1500	68	430	230.0	18.5
	1400	55	374	233.0	15.3
	1300	44	323	239.0	12.5
1200	35	275	247.0	10.2	

Cubic prop demand curve with 3.0 exponent for displacement hulls only.

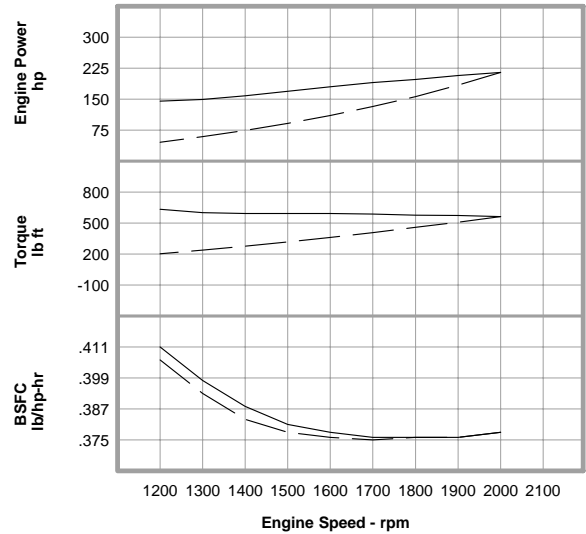

English **Maximum Power** ——— **215 hp**
Prop Demand - - - - -

Performance Data

	Engine Speed rpm	Engine Power hp	Engine Torque lb ft	BSFC lb/hp-hr	Fuel Rate gph
Maximum Power Data	2000	215	563	.378	11.6
	1900	207	573	.376	11.1
	1800	198	577	.376	10.6
	1700	190	586	.376	10.2
	1600	180	591	.378	9.7
	1500	169	591	.381	9.2
	1400	158	591	.388	8.7
	1300	149	601	.398	8.5
1200	145	634	.411	8.5	
Prop Demand Data	2000	215	563	.378	11.6
	1900	184	508	.376	9.9
	1800	156	457	.376	8.4
	1700	132	407	.375	7.1
	1600	110	361	.376	5.9
	1500	91	317	.378	4.9
	1400	74	276	.383	4.0
	1300	59	238	.393	3.3
1200	46	203	.406	2.7	

Power produced at the flywheel will be within standard tolerances up to 50°C (122°F) combustion air temperature measured at the air cleaner inlet, and fuel temperature up to 52°C (125°F) measured at the fuel filter base. Power rated in accordance with NMMA procedure as crankshaft power. Reduce crankshaft power by 3% for propeller shaft power.

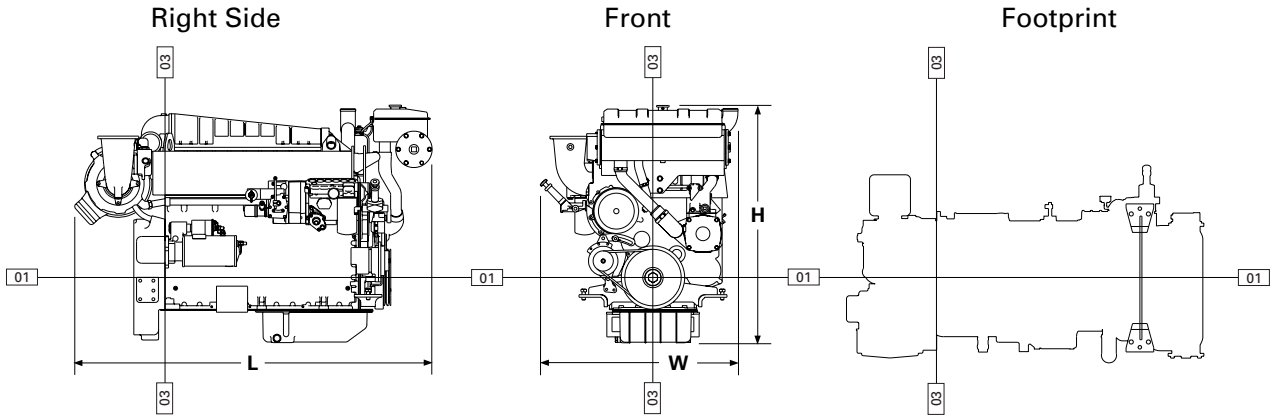

DIMENSIONS

	mm	in.
Overall Length	1719.2	67.7
Length from rear face of block to front of engine	1285.0	50.6
Length from rear face of block to back of flywheel housing	149.8	5.9
Overall Height	1141.0	44.9
Height from crankshaft centerline to top of engine	827.7	32.6
Height from crankshaft centerline to bottom of oil pan	313.3	12.3
Overall Width	951.1	37.4
Width from crankshaft centerline to port side (left side)	372.0	14.7
Width from crankshaft centerline to starboard side (right side)	542.8	21.4
	Front	
	mm	in.
Customer mounting hole diameter	19.8	0.8
Width from crankshaft centerline to mounting holes	307.8	12.1
Length from rear face of block to mounting holes	935.7	36.8
	1018.3	40.1

*Illustrations and dimensions from drawing: 188-1628

RATING DEFINITIONS AND CONDITIONS

A Rating –

Typical Application . . . For heavy-duty service in vessels such as freighters, tugboats, bottom drag trawlers, and deep river towboats where the engine is operated at rated load and speed up to 100% of the time without interruption or load cycling.

- Typical Hours Per Year 5000 to 8000
- Time at Rated Speed Up to 100%
- Load Factor 80 to 100%
- Typical Time at Full Load No limit

Engine Performance Parameters

- Power ±3%
- Specific Fuel Consumption ±3%
- Fuel Rate ±5%

Ratings are based on SAE J1228/ISO8665 standard conditions of 100 kPa (29.61 in. Hg), 25°C (77°F), and 30% relative humidity. These ratings also apply at ISO3046/1, DIN6271/3, and BS5514 conditions of 100 kPa (29.61 in. Hg), 27°C (81°F), and 60% relative humidity.

Fuel rates are based on fuel oil of 35° API [16°C (60°F)] gravity having an LHV of 42 780 kJ/kg (18,390 Btu/lb) when used at 29°C (85°F) and weighing 838.9 g/L (7.001 lb/U.S. gal).

Additional ratings may be available for specific customer requirements. Consult your Caterpillar representative for additional information.



3306B MARINE PROPULSION — 160 bkW (215 bhp)

Performance data is calculated in accordance with tolerances and conditions stated in this specification sheet and is only intended for purposes of comparison with other manufacturers' engines. Actual engine performance may vary according to the particular application of the engine and operating conditions beyond Caterpillar's control.

TMI Reference No.: DM6061-00 (6-19-01)

Materials and specifications are subject to change without notice.

The International System of Units (SI) is used in this publication.

LEHM1242-00 (6-01)

Printed in U.S.A.

Supersedes LEHM7240-01

©2001 Caterpillar
All rights reserved.



Marine Propulsion 3306B Engine

175 kW (235 bhp) 238 mhp @ 2000 rpm

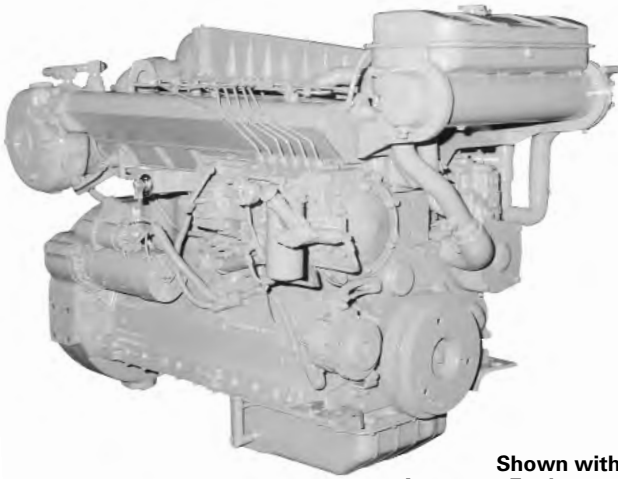

Shown with Accessory Equipment

SPECIFICATIONS

I-6, 4-Stroke-Cycle-Diesel

Emissions	IMO compliant
Displacement	10.5 L (641 cu. in.)
Bore	121 mm (4.8 in.)
Stroke	152 mm (6.0 in.)
Aspiration	Turbocharged-Aftercooled
Governor	Hydra-mechanical
Engine Weight, Net Dry (approx)	1120.9 kg (2469 lb)
Capacity for Liquids	
Cooling System	18.2 L (4.8 U.S. gal)
Lube Oil System (refill)	27.4 L (7.2 U.S. gal)
Oil Change Interval	250 hr
Caterpillar DEO 10W30 or 15W40	
Rotation (from flywheel end)	Counterclockwise

STANDARD EQUIPMENT

Air Inlet System

Dry, regular duty air cleaner

Cooling System

Gear driven centrifugal jacket water pump, engine oil cooler, expansion tank, thermostats and housing, transmission oil cooler

Exhaust System

Watercooled manifold and turbocharger; dry elbow and flange, 152 mm (6 in.)

Flywheel and Flywheel Housing

SAE No. 1 (156 teeth)

Fuel System

Fuel priming pump, fuel transfer pump, fuel filter, flexible fuel lines

Instruments

Fuel pressure gauge, service meter, heavy-duty standard SAE rotation tachometer drive

Lube System

Top-mounted crankcase breather, oil filter, LH oil filler and oil level gauge, oil pan

Mounting System

Front support

General

Vibration damper and guard, Caterpillar yellow paint, lifting eyes

ACCESSORY EQUIPMENT

Air Cleaner Rain Cap

Air Starting Motor

12V 51 Amp, 24V 35 Amp, 24V 60 Amp Alternator

Auxiliary Drive Pulley

Digital Tachometer

Double Wall Fuel Lines and Drain

Duplex Fuel Filter

Electric Overspeed Shutoff

Electric Starting Motor

Engine-Mounted Instrument Panel

Ether Starting Air

Exhaust Elbow, Pipe, Rain Cap, Flexible Fittings

Front Enclosed Clutch

Fuel Ratio Control

Hydraulic Pump Drive

Magnetic Pickup

Manual Shutoff Lever

Manual Sump Pump

Pilot House Instrument Panel

Primary Fuel Filter/Water Separator

Remote-Mounted Pilot House Controls

Remote Positive Locking Governor Control

RH Oil Level Gauge

Shutoff Solenoid — ETR

Spare Parts Kit

PERFORMANCE CURVES

B Rating — DM6060-00

IMO Compliant

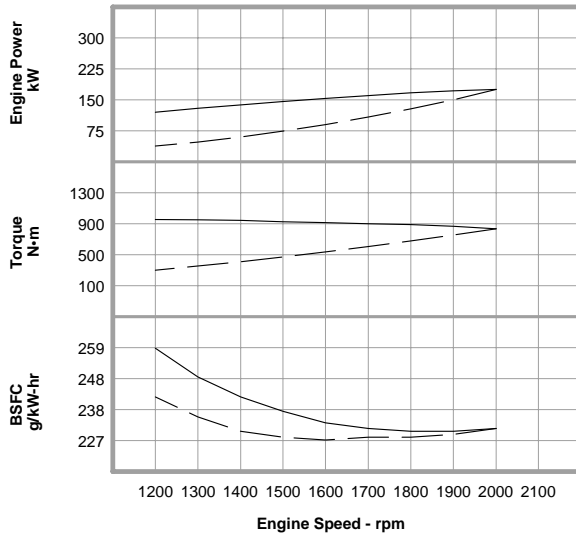

Metric **Maximum Power** **175 kW**
Prop Demand

Performance Data

	Engine Speed rpm	Engine Power kW	Engine Torque N·m	BSFC g/kW-hr	Fuel Rate L/hr
Maximum Power Data	2000	175	836	231.0	48.2
	1900	172	866	230.0	47.2
	1800	167	887	230.0	45.8
	1700	160	901	231.0	44.2
	1600	153	913	233.0	42.6
	1500	146	927	237.0	41.1
	1400	138	941	242.0	39.8
	1300	129	950	249.0	38.4
1200	120	956	259.0	37.0	
Prop Demand Data	2000	175	836	231.0	48.2
	1900	150	754	229.0	41.0
	1800	128	677	228.0	34.7
	1700	108	604	228.0	29.2
	1600	90	535	227.0	24.3
	1500	74	470	228.0	20.0
	1400	60	409	230.0	16.5
	1300	48	353	235.0	13.5
1200	38	301	242.0	10.9	

Cubic prop demand curve with 3.0 exponent for displacement hulls only.

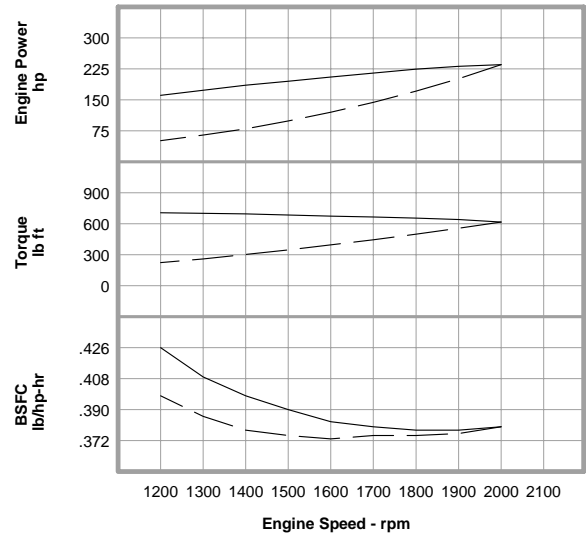

English **Maximum Power** **235 hp**
Prop Demand

Performance Data

	Engine Speed rpm	Engine Power hp	Engine Torque lb ft	BSFC lb/hp-hr	Fuel Rate gph
Maximum Power Data	2000	235	617	.380	12.7
	1900	231	639	.378	12.5
	1800	224	654	.378	12.1
	1700	215	665	.380	11.7
	1600	205	673	.383	11.3
	1500	195	684	.390	10.9
	1400	185	694	.398	10.5
	1300	173	701	.409	10.1
1200	161	705	.426	9.8	
Prop Demand Data	2000	235	617	.380	12.7
	1900	201	556	.376	10.8
	1800	171	499	.375	9.2
	1700	144	445	.375	7.7
	1600	120	395	.373	6.4
	1500	99	347	.375	5.3
	1400	80	302	.378	4.4
	1300	65	260	.386	3.6
1200	51	222	.398	2.9	

Power produced at the flywheel will be within standard tolerances up to 50°C (122°F) combustion air temperature measured at the air cleaner inlet, and fuel temperature up to 52°C (125°F) measured at the fuel filter base. Power rated in accordance with NMMA procedure as crankshaft power. Reduce crankshaft power by 3% for propeller shaft power.

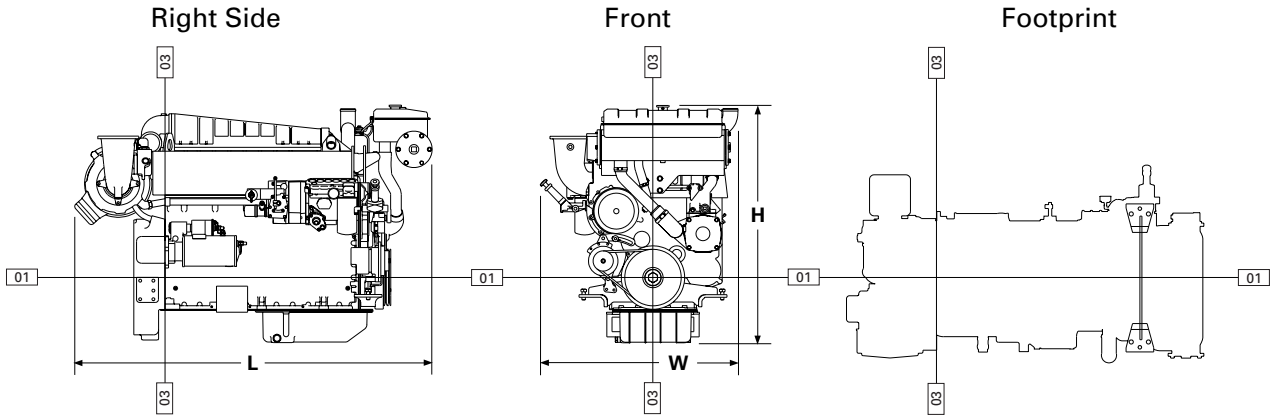

DIMENSIONS

	mm	in.
Overall Length	1719.2	67.7
Length from rear face of block to front of engine	1285.0	50.6
Length from rear face of block to back of flywheel housing	149.8	5.9
Overall Height	1141.0	44.9
Height from crankshaft centerline to top of engine	827.7	32.6
Height from crankshaft centerline to bottom of oil pan	313.3	12.3
Overall Width	951.1	37.4
Width from crankshaft centerline to port side (left side)	372.0	14.7
Width from crankshaft centerline to starboard side (right side)	542.8	21.4
	Front	
	mm	in.
Customer mounting hole diameter	19.8	0.8
Width from crankshaft centerline to mounting holes	307.8	12.1
Length from rear face of block to mounting holes	935.7	36.8
	1018.3	40.1

*Illustrations and dimensions from drawing: 188-1628

RATING DEFINITIONS AND CONDITIONS

B Rating –

Typical Application . . . Vessels such as midwater trawlers, purse seiners, crew and supply boats, ferries, and towboats where locks, sandbars, and curves dictate frequent slowing, and engine load and speed are constant with some cycling.

- Typical Hours Per Year 3000 to 5000
- Time at Rated Speed Up to 80%
- Load Factor 40 to 80%
- Typical Time at Full Load 10 out of 12 hours
- Rated Speed 2000 rpm
- Maximum Cruise Speed 1900 rpm
- Maximum Continuous Cruise Speed 1800 rpm

Engine Performance Parameters

- Power ±3%
- Specific Fuel Consumption ±3%
- Fuel Rate ±5%

Ratings are based on SAE J1228/ISO8665 standard conditions of 100 kPa (29.61 in. Hg), 25°C (77°F), and 30% relative humidity. These ratings also apply at ISO3046/1, DIN6271/3, and BS5514 conditions of 100 kPa (29.61 in. Hg), 27°C (81°F), and 60% relative humidity.

Fuel rates are based on fuel oil of 35° API [16°C (60°F)] gravity having an LHV of 42 780 kJ/kg (18,390 Btu/lb) when used at 29°C (85°F) and weighing 838.9 g/L (7.001 lb/U.S. gal).

Additional ratings may be available for specific customer requirements. Consult your Caterpillar representative for additional information.



3306B MARINE PROPULSION — 175 bkW (235 bhp)

Performance data is calculated in accordance with tolerances and conditions stated in this specification sheet and is only intended for purposes of comparison with other manufacturers' engines. Actual engine performance may vary according to the particular application of the engine and operating conditions beyond Caterpillar's control.

TMI Reference No.: DM6060-00 (6-19-01)

Materials and specifications are subject to change without notice.

The International System of Units (SI) is used in this publication.

LEHM1241-00 (6-01)

Printed in U.S.A.

Supersedes LEHM7240-01

©2001 Caterpillar
All rights reserved.



Marine Propulsion Engine 3306B

201 bkW (270 bhp) 274 mhp @ 2200 rpm

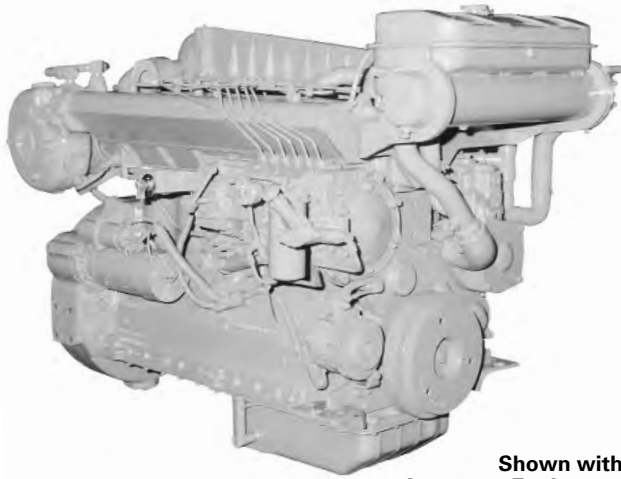

Shown with
Accessory Equipment

SPECIFICATIONS

I-6, 4-Stroke-Cycle-Diesel

Emissions	IMO compliant
Displacement	10.5 L (641 cu. in.)
Bore	121 mm (4.8 in.)
Stroke	152 mm (6.0 in.)
Aspiration	Turbocharged-Aftercooled
Governor	Hydra-mechanical
Engine Weight, Net Dry (approx)	1120.9 kg (2469 lb)
Capacity for Liquids	
Cooling System	18.2 L (4.8 U.S. gal)
Lube Oil System (refill)	27.4 L (7.2 U.S. gal)
Oil Change Interval	250 hr
Caterpillar DEO	10W30 or 15W40
Rotation (from flywheel end)	Counterclockwise

STANDARD EQUIPMENT

Air Inlet System

Dry, regular duty air cleaner

Cooling System

Gear driven centrifugal jacket water pump, engine oil cooler, expansion tank, thermostats and housing, transmission oil cooler

Exhaust System

Watercooled manifold and turbocharger; dry elbow and flange, 152 mm (6 in.)

Flywheel and Flywheel Housing

SAE No. 1 (156 teeth)

Fuel System

Fuel priming pump, fuel transfer pump, fuel filter, flexible fuel lines

Instruments

Fuel pressure gauge, service meter, heavy-duty standard SAE rotation tachometer drive

Lube System

Top-mounted crankcase breather, oil filter, LH oil filler and oil level gauge, oil pan

Mounting System

Front support

General

Vibration damper and guard, Caterpillar yellow paint, lifting eyes

ACCESSORY EQUIPMENT

Air Cleaner Rain Cap

Air Starting Motor

12V 51 Amp, 24V 35 Amp, 24V 60 Amp Alternator

Auxiliary Drive Pulley

Digital Tachometer

Double Wall Fuel Lines and Drain

Duplex Fuel Filter

Electric Overspeed Shutoff

Electric Starting Motor

Engine-Mounted Instrument Panel

Ether Starting Air

Exhaust Elbow, Pipe, Rain Cap, Flexible Fittings

Front Enclosed Clutch

Fuel Ratio Control

Hydraulic Pump Drive

Magnetic Pickup

Manual Shutoff Lever

Manual Sump Pump

Pilot House Instrument Panel

Primary Fuel Filter/Water Separator

Remote-Mounted Pilot House Controls

Remote Positive Locking Governor Control

RH Oil Level Gauge

Shutoff Solenoid — ETR

Spare Parts Kit

PERFORMANCE CURVES

C Rating — DM6059-00

IMO Compliant

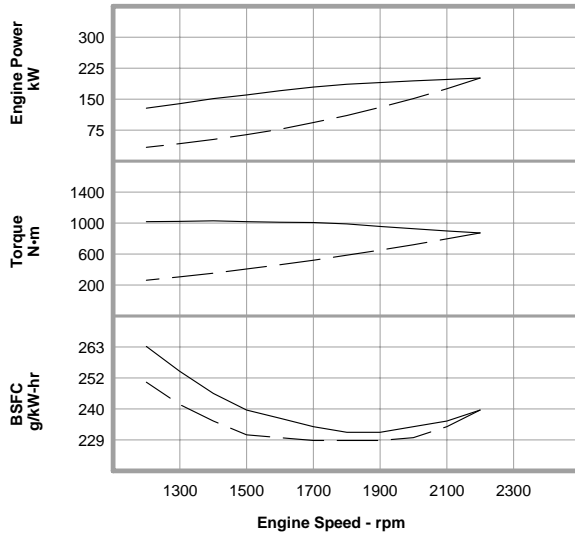

Metric **Maximum Power** ——— **201 kW**
Prop Demand - - - - -

Performance Data

	Engine Speed rpm	Engine Power kW	Engine Torque N·m	BSFC g/kW-hr	Fuel Rate L/hr
Maximum Power Data	2200	201	872	240.0	57.6
	2100	198	900	236.0	55.8
	2000	194	926	234.0	54.0
	1900	190	955	232.0	52.5
	1800	186	987	232.0	51.4
	1700	179	1005	234.0	49.9
	1600	170	1012	237.0	47.8
	1500	160	1019	240.0	45.8
	1400	151	1030	246.0	44.3
	1300	139	1021	254.0	42.0
1200	128	1019	263.0	40.2	
Prop Demand Data	2200	201	872	240.0	57.6
	2100	175	795	234.0	48.8
	2000	151	721	230.0	41.5
	1900	130	651	229.0	35.4
	1800	110	584	229.0	30.0
	1700	93	521	229.0	25.3
	1600	77	461	230.0	21.2
	1500	64	406	231.0	17.6
	1400	52	353	236.0	14.5
	1300	42	305	242.0	12.0
1200	33	260	250.0	9.7	

Cubic prop demand curve with 3.0 exponent for displacement hulls only.

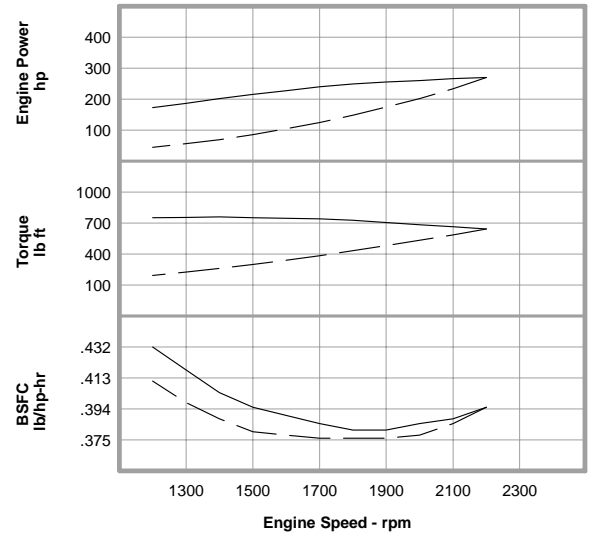

English **Maximum Power** ——— **270 hp**
Prop Demand - - - - -

Performance Data

	Engine Speed rpm	Engine Power hp	Engine Torque lb ft	BSFC lb/hp-hr	Fuel Rate gph
Maximum Power Data	2200	270	643	.395	15.2
	2100	266	664	.388	14.7
	2000	260	683	.385	14.3
	1900	255	704	.381	13.9
	1800	249	728	.381	13.6
	1700	240	741	.385	13.2
	1600	227	746	.390	12.6
	1500	215	752	.395	12.1
	1400	202	760	.404	11.7
	1300	186	753	.418	11.1
1200	172	752	.432	10.6	
Prop Demand Data	2200	270	643	.395	15.2
	2100	234	586	.385	12.9
	2000	202	532	.378	11.0
	1900	174	480	.376	9.4
	1800	148	431	.376	7.9
	1700	124	384	.376	6.7
	1600	104	340	.378	5.6
	1500	85	299	.380	4.6
	1400	69	260	.388	3.8
	1300	56	225	.398	3.2
1200	44	192	.411	2.6	

Power produced at the flywheel will be within standard tolerances up to 50°C (122°F) combustion air temperature measured at the air cleaner inlet, and fuel temperature up to 52°C (125°F) measured at the fuel filter base. Power rated in accordance with NMMA procedure as crankshaft power. Reduce crankshaft power by 3% for propeller shaft power.

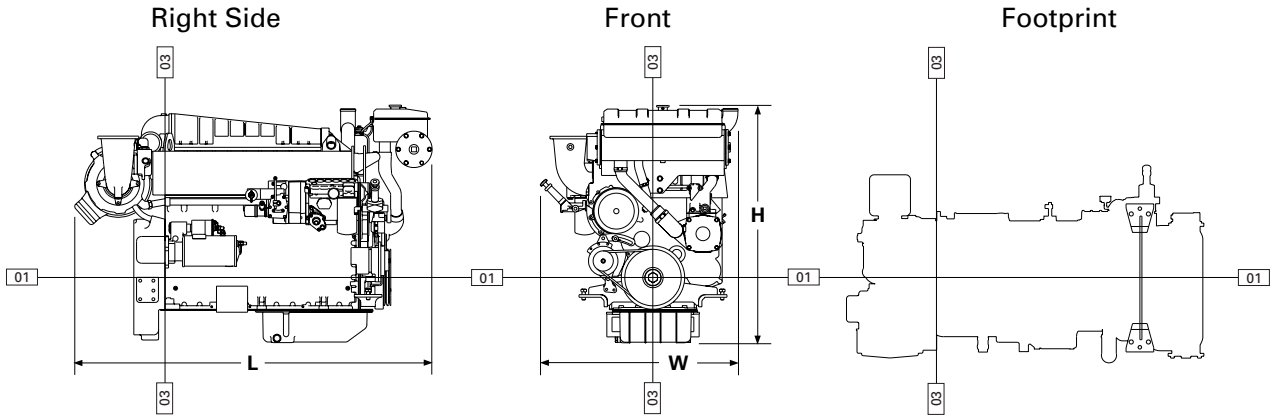

DIMENSIONS

	mm	in.
Overall Length	1719.2	67.7
Length from rear face of block to front of engine	1285.0	50.6
Length from rear face of block to back of flywheel housing	149.8	5.9
Overall Height	1141.0	44.9
Height from crankshaft centerline to top of engine	827.7	32.6
Height from crankshaft centerline to bottom of oil pan	313.3	12.3
Overall Width	951.1	37.4
Width from crankshaft centerline to port side (left side)	372.0	14.7
Width from crankshaft centerline to starboard side (right side)	542.8	21.4
	Front	
	mm	in.
Customer mounting hole diameter	19.8	0.8
Width from crankshaft centerline to mounting holes	307.8	12.1
Length from rear face of block to mounting holes	935.7	36.8
	1018.3	40.1

*Illustrations and dimensions from drawing: 188-1628

RATING DEFINITIONS AND CONDITIONS

C Rating –

Typical Application . . . Vessels such as ferries, harbor tugs, fishing boats moving at higher speeds out and back (e.g. lobster, crayfish, and tuna), offshore service boats, and also displacement hull yachts and short trip coastal freighters where engine load and speed are cyclical.

Typical Hours Per Year 2000 to 4000

Time at Rated Speed Up to 50%

Load Factor 20 to 80%

Typical Time at Full Load 6 out of 12 hours

Rated Speed 2200 rpm

Maximum Cruise Speed 2100 rpm

Maximum Continuous Cruise Speed 2000 rpm

Engine Performance Parameters

Power	±3%
Specific Fuel Consumption	±3%
Fuel Rate	±5%

Ratings are based on SAE J1228/ISO8665 standard conditions of 100 kPa (29.61 in. Hg), 25°C (77°F), and 30% relative humidity. These ratings also apply at ISO3046/1, DIN6271/3, and BS5514 conditions of 100 kPa (29.61 in. Hg), 27°C (81°F), and 60% relative humidity.

Fuel rates are based on fuel oil of 35° API [16°C (60°F)] gravity having an LHV of 42 780 kJ/kg (18,390 Btu/lb) when used at 29°C (85°F) and weighing 838.9 g/L (7.001 lb/U.S. gal).

Additional ratings may be available for specific customer requirements. Consult your Caterpillar representative for additional information.

Performance data is calculated in accordance with tolerances and conditions stated in this specification sheet and is only intended for purposes of comparison with other manufacturers' engines. Actual engine performance may vary according to the particular application of the engine and operating conditions beyond Caterpillar's control.

TMI Reference No.: DM6059-00 (6-19-01)

Materials and specifications are subject to change without notice.

The International System of Units (SI) is used in this publication.

LEHM1240-00 (6-01)

Printed in U.S.A.

Supersedes LEHM7240-01

©2001 Caterpillar
All rights reserved.



Marine Propulsion 3306B Engine

175 bkW (235 bhp) 238 mhp @ 2000 rpm

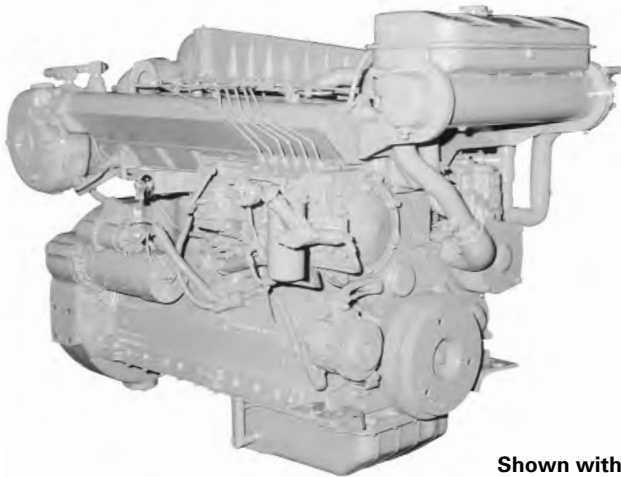

Shown with
Accessory Equipment

STANDARD EQUIPMENT

Air Inlet System

Dry, regular duty air cleaner

Cooling System

Gear driven, self-priming auxiliary sea water pump with rotary rubber impeller; gear driven centrifugal jacket water pump; engine oil cooler; expansion tank; engine mounted heat exchanger with removable tube bundle and replaceable copper-nickel tubes; thermostats and housing

Exhaust System

Watercooled manifold and turbocharger; dry elbow and flange, 152 mm (6 in.)

Flywheel and Flywheel Housing

SAE No. 1 (156 teeth)

Fuel System

Fuel priming pump, fuel transfer pump, fuel filter, flexible fuel lines

Instruments

Fuel pressure gauge, service meter, heavy-duty standard SAE rotation tachometer drive

Lube System

Top-mounted crankcase breather, oil filter, LH oil filler and oil level gauge, oil pan

Mounting System

Front support

General

Vibration damper and guard, Caterpillar yellow paint, lifting eyes

SPECIFICATIONS

I-6, 4-Stroke-Cycle-Diesel

Emissions	IMO compliant
Displacement	10.5 L (641 cu in.)
Bore	121 mm (4.8 in.)
Stroke	152 mm (6.0 in.)
Aspiration	Turbocharged-Aftercooled
Governor	Hydra-mechanical
Engine Weight, Net Dry (approx)	1120.9 kg (2469 lb)
Capacity for Liquids	
Cooling System	18.2 L (4.8 U.S. gal)
Lube Oil System (refill)	27.4 L (7.2 U.S. gal)
Oil Change Interval	250 hr
Caterpillar DEO 10W30 or 15W40	
Rotation (from flywheel end)	Counterclockwise

ACCESSORY EQUIPMENT

Air Cleaner Rain Cap

Air Starting Motor

12V 51 Amp, 24V 35 Amp, 24V 60 Amp Alternator

Auxiliary Drive Pulley

Digital Tachometer

Double Wall Fuel Lines and Drain

Duplex Fuel Filter

Electric Overspeed Shutoff

Electric Starting Motor

Engine-Mounted Instrument Panel

Ether Starting Aid

Exhaust Elbow, Pipe, Rain Cap, Flexible Fittings

Front Enclosed Clutch

Fuel Ratio Control

Hydraulic Pump Drive

Magnetic Pickup

Manual Shutoff Lever

Manual Sump Pump

Pilot House Instrument Panel

Primary Fuel Filter/Water Separator

Remote-Mounted Pilot House Controls

Remote Positive Locking Governor Control

RH Oil Level Gauge

Shutoff Solenoid — ETR

Spare Parts Kit

PERFORMANCE CURVES

A Rating — DM6056-00

IMO Compliant

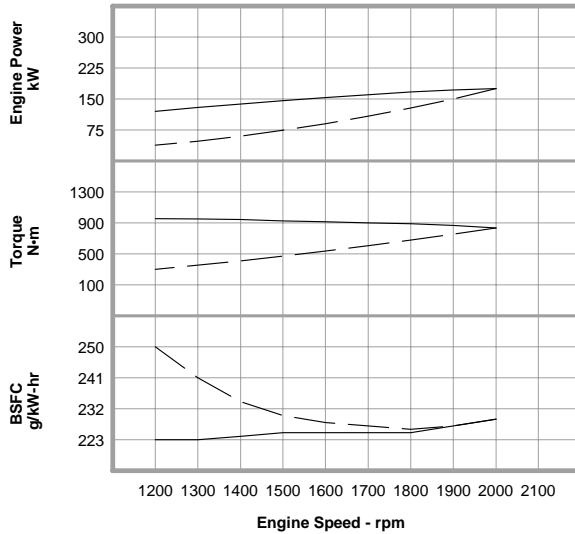

Metric Maximum Power ——— Prop Demand - - - - 175 kW

Performance Data

	Engine Speed rpm	Engine Power kW	Engine Torque N·m	BSFC g/kW-hr	Fuel Rate L/hr
Maximum Power Data	2000	175	836	229.0	47.7
	1900	172	866	227.0	46.6
	1800	167	887	225.0	44.9
	1700	160	901	225.0	43.0
	1600	153	913	225.0	41.0
	1500	146	927	225.0	39.0
	1400	138	941	224.0	36.8
	1300	129	950	223.0	34.4
	1200	120	956	223.0	32.0
	Prop Demand Data	2000	175	836	229.0
1900		150	754	227.0	40.6
1800		128	677	226.0	34.4
1700		108	604	227.0	29.0
1600		90	535	228.0	24.3
1500		74	470	230.0	20.3
1400		60	409	234.0	16.8
1300		48	353	241.0	13.8
1200		38	301	250.0	11.3

Cubic prop demand curve with 3.0 exponent for displacement hulls only.

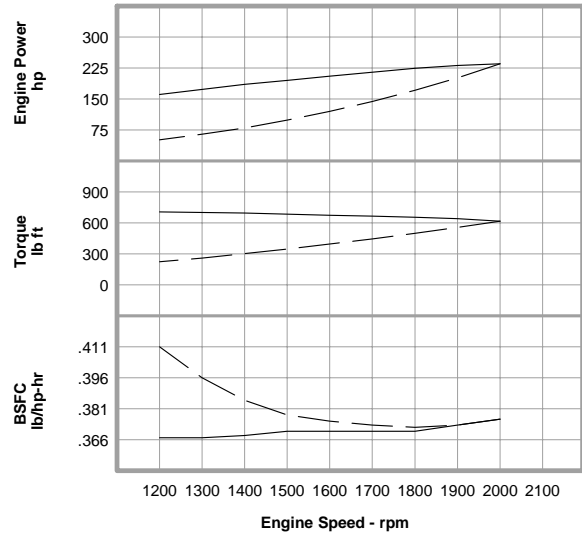

English Maximum Power ——— Prop Demand - - - - 235 hp

Performance Data

	Engine Speed rpm	Engine Power hp	Engine Torque lb ft	BSFC lb/hp-hr	Fuel Rate gph
Maximum Power Data	2000	235	617	.376	12.6
	1900	231	639	.373	12.3
	1800	224	654	.370	11.9
	1700	215	665	.370	11.4
	1600	205	673	.370	10.8
	1500	195	684	.370	10.3
	1400	185	694	.368	9.7
	1300	173	701	.367	9.1
	1200	161	705	.367	8.5
	Prop Demand Data	2000	235	617	.376
1900		201	556	.373	10.7
1800		171	499	.372	9.1
1700		144	445	.373	7.7
1600		120	395	.375	6.4
1500		99	347	.378	5.4
1400		80	302	.385	4.4
1300		65	260	.396	3.6
1200		51	222	.411	3.0

Power produced at the flywheel will be within standard tolerances up to 50°C (122°F) combustion air temperature measured at the air cleaner inlet, and fuel temperature up to 52°C (125°F) measured at the fuel filter base. Power rated in accordance with NMMA procedure as crankshaft power. Reduce crankshaft power by 3% for propeller shaft power.

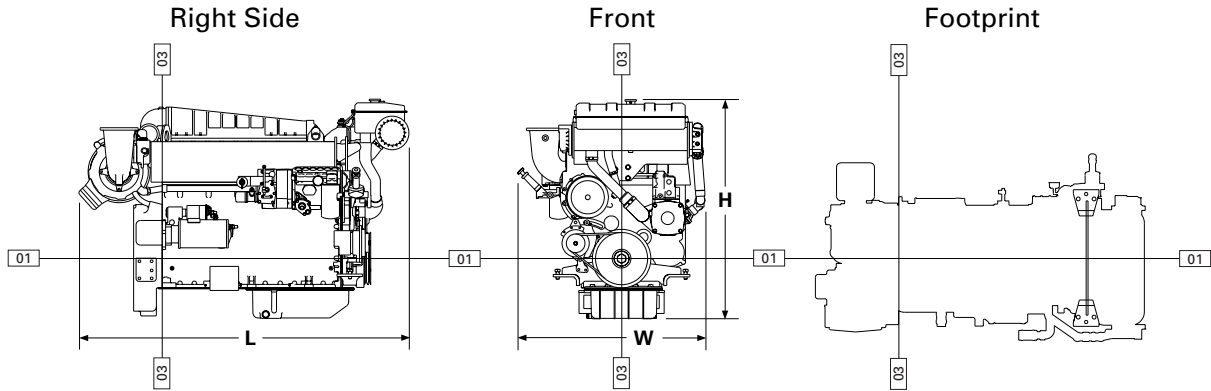

DIMENSIONS*

	mm	in.
Overall Length	1719.2	67.7
Length from rear face of block to front of engine	1285.0	50.6
Length from rear face of block to back of flywheel housing	149.8	5.9
Overall Height	1141.0	44.9
Height from crankshaft centerline to top of engine	827.7	32.6
Height from crankshaft centerline to bottom of oil pan	313.3	12.3
Overall Width	977.6	38.5
Width from crankshaft centerline to port side (left side)	434.8	17.1
Width from crankshaft centerline to starboard side (right side)	542.8	21.4
	Front	
	mm	in.
Customer mounting hole diameter	19.8	0.8
Width from crankshaft centerline to mounting holes	307.8	12.1
Length from rear face of block to mounting holes	935.7	36.8
	1018.3	40.1

*Illustrations and dimensions from drawing: 118-7821

RATING DEFINITIONS AND CONDITIONS

A Rating –

Typical Application . . . For heavy-duty service in vessels such as freighters, tugboats, bottom drag trawlers, and deep river towboats where the engine is operated at rated load and speed up to 100% of the time without interruption or load cycling.

- Typical Hours Per Year 5000 to 8000
- Time at Rated Speed Up to 100%
- Load Factor 80 to 100%
- Typical Time at Full Load No limit

Engine Performance Parameters

- Power ±3%
- Specific Fuel Consumption ±3%
- Fuel Rate ±5%

Ratings are based on SAE J1228/ISO8665 standard conditions of 100 kPa (29.61 in. Hg), 25°C (77°F), and 30% relative humidity. These ratings also apply at ISO3046/1, DIN6271/3, and BS5514 conditions of 100 kPa (29.61 in. Hg), 27°C (81°F), and 60% relative humidity.

Fuel rates are based on fuel oil of 35° API [16°C (60°F)] gravity having an LHV of 42 780 kJ/kg (18,390 Btu/lb) when used at 29°C (85°F) and weighing 838.9 g/L (7.001 lb/U.S. gal).

Additional ratings may be available for specific customer requirements. Consult your Caterpillar representative for additional information.



3306B MARINE PROPULSION — 175 bkW (235 bhp)

Performance data is calculated in accordance with tolerances and conditions stated in this specification sheet and is only intended for purposes of comparison with other manufacturers' engines. Actual engine performance may vary according to the particular application of the engine and operating conditions beyond Caterpillar's control.

TMI Reference No.: DM6056-00 (6-19-01)

Materials and specifications are subject to change without notice.

The International System of Units (SI) is used in this publication.

LEHM1239-00 (6-01)

Printed in U.S.A.

Supersedes LEHM7240-01

©2001 Caterpillar
All rights reserved.



Marine Propulsion 3306B Engine

187 kW (250 bhp) 254 mhp @ 2000 rpm

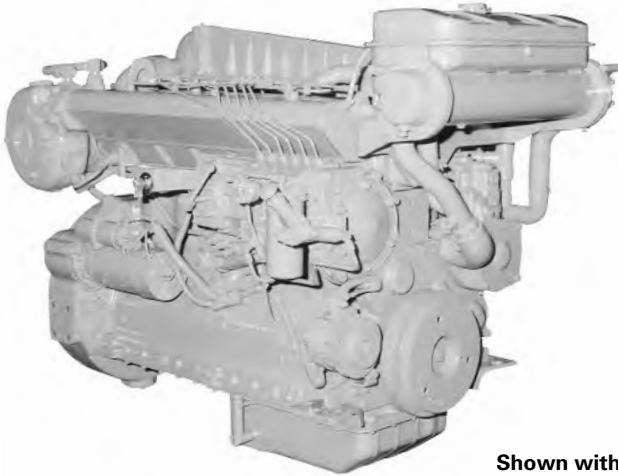

Shown with
Accessory Equipment

STANDARD EQUIPMENT

Air Inlet System

Dry, regular duty air cleaner

Cooling System

Gear driven, self-priming auxiliary sea water pump with rotary rubber impeller; gear driven centrifugal jacket water pump; engine oil cooler; expansion tank; engine mounted heat exchanger with removable tube bundle and replaceable copper-nickel tubes; thermostats and housing

Exhaust System

Watercooled manifold and turbocharger; dry elbow and flange, 152 mm (6 in.)

Flywheel and Flywheel Housing

SAE No. 1 (156 teeth)

Fuel System

Fuel priming pump, fuel transfer pump, fuel filter, flexible fuel lines

Instruments

Fuel pressure gauge, service meter, heavy-duty standard SAE rotation tachometer drive

Lube System

Top-mounted crankcase breather, oil filter, LH oil filler and oil level gauge, oil pan

Mounting System

Front support

General

Vibration damper and guard, Caterpillar yellow paint, lifting eyes

SPECIFICATIONS

I-6, 4-Stroke-Cycle-Diesel

Emissions	IMO compliant
Displacement	10.5 L (641 cu. in.)
Bore	121 mm (4.8 in.)
Stroke	152 mm (6.0 in.)
Aspiration	Turbocharged-Aftercooled
Governor	Hydra-mechanical
Engine Weight, Net Dry (approx)	1120.9 kg (2469 lb)
Capacity for Liquids	
Cooling System	18.2 L (4.8 U.S. gal)
Lube Oil System (refill)	27.4 L (7.2 U.S. gal)
Oil Change Interval	250 hr
Caterpillar DEO 10W30 or 15W40	
Rotation (from flywheel end)	Counterclockwise

ACCESSORY EQUIPMENT

Air Cleaner Rain Cap

Air Starting Motor

12V 51 Amp, 24V 35 Amp, 24V 60 Amp Alternator

Auxiliary Drive Pulley

Digital Tachometer

Double Wall Fuel Lines and Drain

Duplex Fuel Filter

Electric Overspeed Shutoff

Electric Starting Motor

Engine-Mounted Instrument Panel

Ether Starting Aid

Exhaust Elbow, Pipe, Rain Cap, Flexible Fittings

Front Enclosed Clutch

Fuel Ratio Control

Hydraulic Pump Drive

Magnetic Pickup

Manual Shutoff Lever

Manual Sump Pump

Pilot House Instrument Panel

Primary Fuel Filter/Water Separator

Remote-Mounted Pilot House Controls

Remote Positive Locking Governor Control

RH Oil Level Gauge

Shutoff Solenoid — ETR

Spare Parts Kit

PERFORMANCE CURVES

B Rating — DM6055-00

IMO Compliant

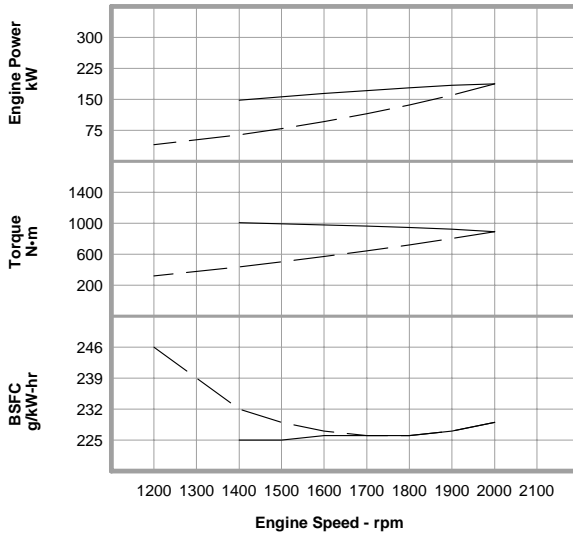

Metric **Maximum Power** ——— **187 kW**
Prop Demand - - - - -

Performance Data

	Engine Speed rpm	Engine Power kW	Engine Torque N·m	BSFC g/kW-hr	Fuel Rate L/hr
Maximum Power Data	2000	187	891	229.0	50.9
	1900	184	924	227.0	48.8
	1800	178	946	226.0	48.1
	1700	171	962	226.0	46.1
	1600	164	976	226.0	44.0
	1500	156	993	225.0	41.9
	1400	148	1007	225.0	39.5
Prop Demand Data	2000	187	890	229.0	50.9
	1900	160	804	227.0	43.2
	1800	136	721	226.0	36.6
	1700	115	643	226.0	30.8
	1600	96	570	227.0	25.8
	1500	79	501	229.0	21.4
	1400	64	436	232.0	17.7
1200	40	321	246.0	11.8	

Cubic prop demand curve with 3.0 exponent for displacement hulls only.

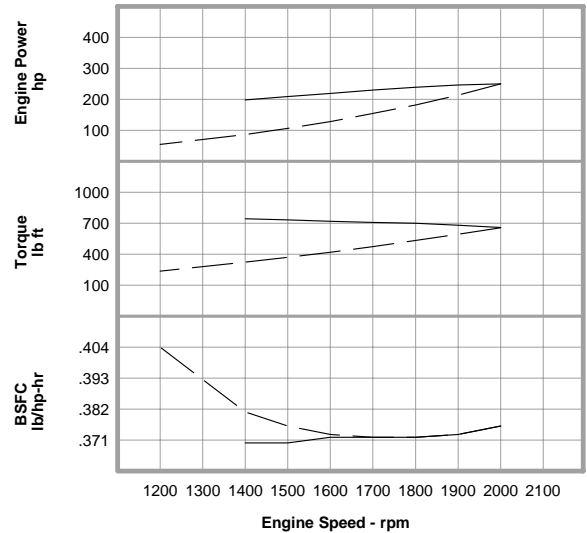

English **Maximum Power** ——— **250 hp**
Prop Demand - - - - -

Performance Data

	Engine Speed rpm	Engine Power hp	Engine Torque lb ft	BSFC lb/hp-hr	Fuel Rate gph
Maximum Power Data	2000	250	657	.376	13.4
	1900	246	681	.373	13.2
	1800	239	698	.372	12.7
	1700	230	709	.372	12.2
	1600	219	720	.372	11.6
	1500	209	732	.370	11.1
	1400	198	743	.370	10.4
Prop Demand Data	2000	250	656	.376	13.4
	1900	214	593	.373	11.4
	1800	182	532	.372	9.7
	1700	154	474	.372	8.1
	1600	128	420	.373	6.8
	1500	106	369	.376	5.7
	1400	86	322	.381	4.7
1200	54	237	.404	3.1	

Power produced at the flywheel will be within standard tolerances up to 50°C (122°F) combustion air temperature measured at the air cleaner inlet, and fuel temperature up to 52°C (125°F) measured at the fuel filter base. Power rated in accordance with NMMA procedure as crankshaft power. Reduce crankshaft power by 3% for propeller shaft power.

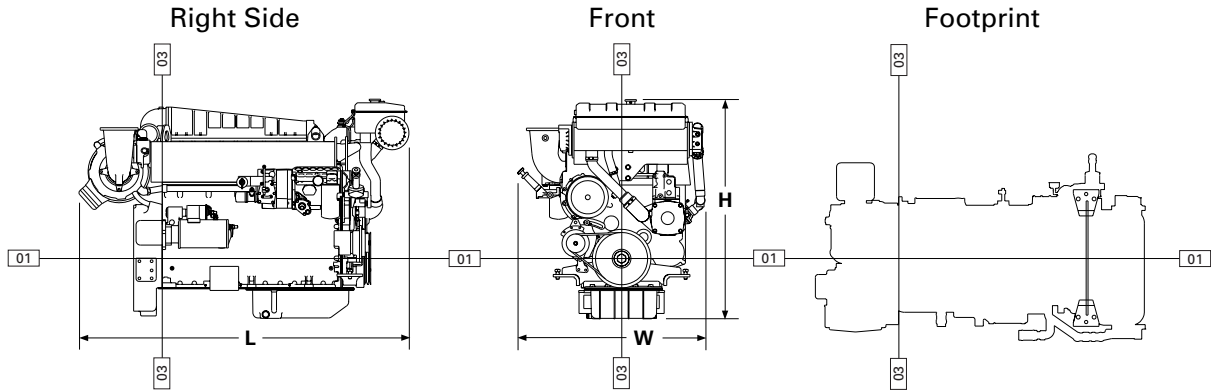

DIMENSIONS*

	mm	in.
Overall Length	1719.2	67.7
Length from rear face of block to front of engine	1285.0	50.6
Length from rear face of block to back of flywheel housing	149.8	5.9
Overall Height	1141.0	44.9
Height from crankshaft centerline to top of engine	827.7	32.6
Height from crankshaft centerline to bottom of oil pan	313.3	12.3
Overall Width	977.6	38.5
Width from crankshaft centerline to port side (left side)	434.8	17.1
Width from crankshaft centerline to starboard side (right side)	542.8	21.4
	Front	
	mm	in.
Customer mounting hole diameter	19.8	0.8
Width from crankshaft centerline to mounting holes	307.8	12.1
Length from rear face of block to mounting holes	935.7	36.8
	1018.3	40.1

*Illustrations and dimensions from drawing: 118-7821

RATING DEFINITIONS AND CONDITIONS

B Rating –

Typical Application . . . Vessels such as midwater trawlers, purse seiners, crew and supply boats, ferries, and towboats where locks, sandbars, and curves dictate frequent slowing, and engine load and speed are constant with some cycling.

- Typical Hours Per Year 3000 to 5000
- Time at Rated Speed Up to 80%
- Load Factor 40 to 80%
- Typical Time at Full Load 10 out of 12 hours
- Rated Speed 2000 rpm
- Maximum Cruise Speed 1900 rpm
- Maximum Continuous Cruise Speed 1800 rpm

Engine Performance Parameters

- Power ±3%
- Specific Fuel Consumption ±3%
- Fuel Rate ±5%

Ratings are based on SAE J1228/ISO8665 standard conditions of 100 kPa (29.61 in. Hg), 25°C (77°F), and 30% relative humidity. These ratings also apply at ISO3046/1, DIN6271/3, and BS5514 conditions of 100 kPa (29.61 in. Hg), 27°C (81°F), and 60% relative humidity.

Fuel rates are based on fuel oil of 35° API [16°C (60°F)] gravity having an LHV of 42 780 kJ/kg (18,390 Btu/lb) when used at 29°C (85°F) and weighing 838.9 g/L (7.001 lb/U.S. gal).

Additional ratings may be available for specific customer requirements. Consult your Caterpillar representative for additional information.



3306B MARINE PROPULSION — 187 bkW (250 bhp)

Performance data is calculated in accordance with tolerances and conditions stated in this specification sheet and is only intended for purposes of comparison with other manufacturers' engines. Actual engine performance may vary according to the particular application of the engine and operating conditions beyond Caterpillar's control.

TMI Reference No.: DM6055-00 (6-19-01)

Materials and specifications are subject to change without notice.

The International System of Units (SI) is used in this publication.

LEHM1238-00 (6-01)

Printed in U.S.A.

Supersedes LEHM7240-01

©2001 Caterpillar
All rights reserved.



Marine Propulsion Engine 3306B

235 bkW (315 bhp) 319 mhp @ 2200 rpm

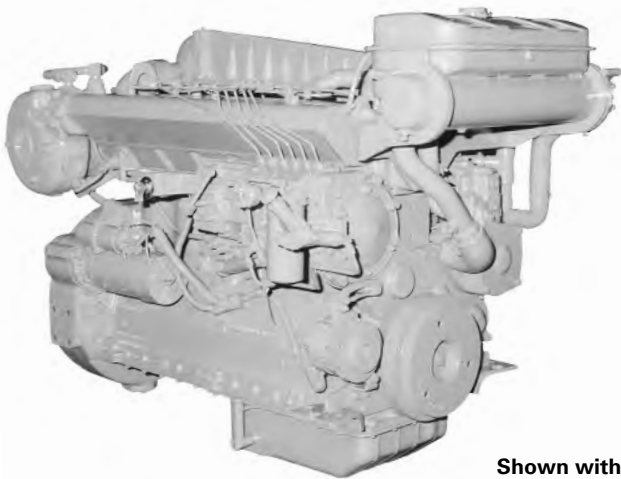

Shown with
Accessory Equipment

STANDARD EQUIPMENT

Air Inlet System

Dry, regular duty air cleaner

Cooling System

Gear driven centrifugal jacket water pump, engine oil cooler, expansion tank, thermostats and housing, transmission oil cooler

Exhaust System

Watercooled manifold and turbocharger; dry elbow and flange, 152 mm (6 in.)

Flywheel and Flywheel Housing

SAE No. 1 (156 teeth)

Fuel System

Fuel priming pump, fuel transfer pump, fuel filter, flexible fuel lines

Instruments

Fuel pressure gauge, service meter, heavy-duty standard SAE rotation tachometer drive

Lube System

Top-mounted crankcase breather, oil filter, LH oil filler and oil level gauge, oil pan

Mounting System

Front support

General

Vibration damper and guard, Caterpillar yellow paint, lifting eyes

SPECIFICATIONS

I-6, 4-Stroke-Cycle-Diesel

Emissions	IMO compliant
Displacement	10.5 L (641 cu. in.)
Bore	121 mm (4.8 in.)
Stroke	152 mm (6.0 in.)
Aspiration	Turbocharged-Aftercooled
Governor	Hydra-mechanical
Engine Weight, Net Dry (approx)	1120.9 kg (2469 lb)
Capacity for Liquids	
Cooling System	18.2 L (4.8 U.S. gal)
Lube Oil System (refill)	27.4 L (7.2 U.S. gal)
Oil Change Interval	250 hr
Caterpillar DEO 10W30 or 15W40	
Rotation (from flywheel end)	Counterclockwise

ACCESSORY EQUIPMENT

Air Cleaner Rain Cap

Air Starting Motor

12V 51 Amp, 24V 35 Amp, 24V 60 Amp Alternator

Auxiliary Drive Pulley

Digital Tachometer

Double Wall Fuel Lines and Drain

Duplex Fuel Filter

Electric Overspeed Shutoff

Electric Starting Motor

Engine-Mounted Instrument Panel

Ether Starting Air

Exhaust Elbow, Pipe, Rain Cap, Flexible Fittings

Front Enclosed Clutch

Fuel Ratio Control

Hydraulic Pump Drive

Magnetic Pickup

Manual Shutoff Lever

Manual Sump Pump

Pilot House Instrument Panel

Primary Fuel Filter/Water Separator

Remote-Mounted Pilot House Controls

Remote Positive Locking Governor Control

RH Oil Level Gauge

Shutoff Solenoid — ETR

Spare Parts Kit

PERFORMANCE CURVES

D Rating — DM6058-00

IMO Compliant

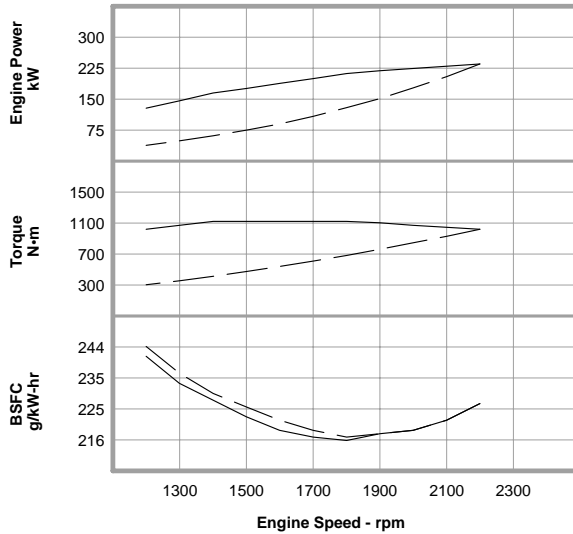

Metric **Maximum Power** **235 kW**
Prop Demand

Performance Data

	Engine Speed rpm	Engine Power kW	Engine Torque N·m	BSFC g/kW-hr	Fuel Rate L/hr
Maximum Power Data	2200	235	1020	227.0	63.5
	2100	230	1046	222.0	60.9
	2000	224	1071	219.0	58.7
	1900	219	1102	218.0	56.8
	1800	212	1122	216.0	54.6
	1700	200	1122	217.0	51.7
	1600	188	1122	219.0	49.1
	1500	176	1122	223.0	46.8
	1400	165	1122	228.0	44.6
	1300	146	1071	233.0	40.6
1200	128	1020	241.0	36.8	
Prop Demand Data	2200	235	1020	227.0	63.5
	2100	204	929	222.0	54.0
	2000	177	843	219.0	46.1
	1900	151	761	218.0	39.3
	1800	129	683	217.0	33.3
	1700	108	609	219.0	28.2
	1600	90	540	222.0	23.9
	1500	75	474	226.0	20.0
	1400	61	413	230.0	16.6
	1300	49	356	236.0	13.7
1200	38	303	244.0	11.1	

Cubic prop demand curve with 3.0 exponent for displacement hulls only.

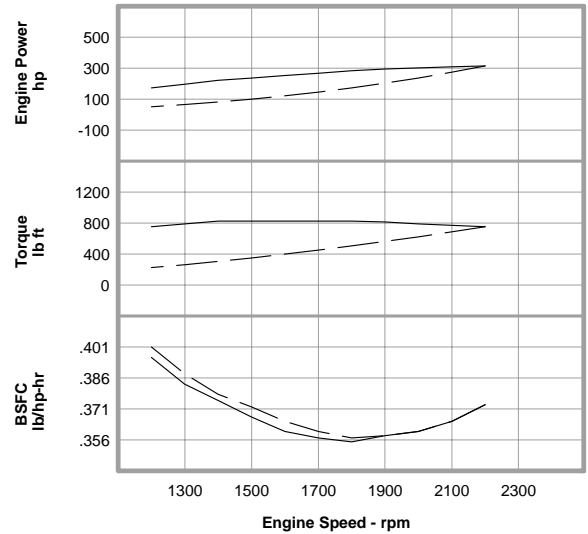

English **Maximum Power** **315 hp**
Prop Demand

Performance Data

	Engine Speed rpm	Engine Power hp	Engine Torque lb ft	BSFC lb/hp-hr	Fuel Rate gph
Maximum Power Data	2200	315	752	.373	16.8
	2100	308	771	.365	16.1
	2000	301	790	.360	15.5
	1900	294	813	.358	15.0
	1800	284	827	.355	14.4
	1700	268	827	.357	13.7
	1600	252	827	.360	13.0
	1500	236	827	.367	12.4
	1400	221	827	.375	11.8
	1300	196	790	.383	10.7
1200	172	752	.396	9.7	
Prop Demand Data	2200	315	752	.373	16.8
	2100	274	685	.365	14.3
	2000	237	622	.360	12.2
	1900	203	561	.358	10.4
	1800	173	504	.357	8.8
	1700	145	449	.360	7.4
	1600	121	398	.365	6.3
	1500	100	350	.372	5.3
	1400	81	305	.378	4.4
	1300	65	263	.388	3.6
1200	51	223	.401	2.9	

Power produced at the flywheel will be within standard tolerances up to 50°C (122°F) combustion air temperature measured at the air cleaner inlet, and fuel temperature up to 52°C (125°F) measured at the fuel filter base. Power rated in accordance with NMMA procedure as crankshaft power. Reduce crankshaft power by 3% for propeller shaft power.

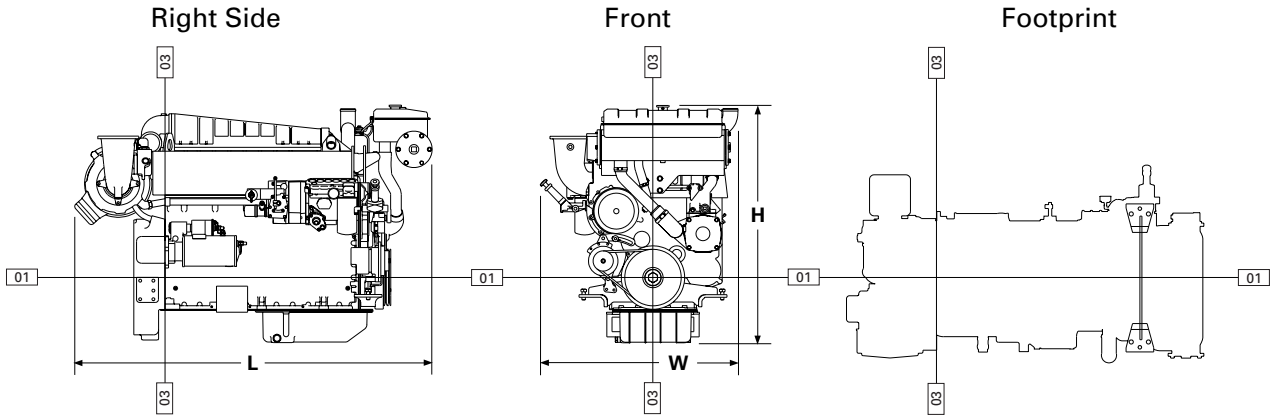

DIMENSIONS*

	mm	in.
Overall Length	1719.2	67.7
Length from rear face of block to front of engine	1285.0	50.6
Length from rear face of block to back of flywheel housing	149.8	5.9
Overall Height	1141.0	44.9
Height from crankshaft centerline to top of engine	827.7	32.6
Height from crankshaft centerline to bottom of oil pan	313.3	12.3
Overall Width	951.1	37.4
Width from crankshaft centerline to port side (left side)	372.0	14.7
Width from crankshaft centerline to starboard side (right side)	542.8	21.4
	Front	
	mm	in.
Customer mounting hole diameter	19.8	0.8
Width from crankshaft centerline to mounting holes	307.8	12.1
Length from rear face of block to mounting holes	935.7	36.8
	1018.3	40.1

*Illustrations and dimensions from drawing: 188-1628

RATING DEFINITIONS AND CONDITIONS

D Rating –

Typical Application . . . Planing hull vessels such as offshore patrol boats, customs, police, and some fire and fishing boats. Also used for bow and stern thrusters.

Typical Hours Per Year 1000 to 3000
 Time at Rated Speed Up to 16%
 Load Factor Up to 50%
 Typical Time at Full Load 2 out of 12 hours

Rated Speed 2200 rpm
 Maximum Cruise Speed 2050 rpm
 Maximum Continuous Cruise Speed 1900 rpm

Engine Performance Parameters

Power ±3%
 Specific Fuel Consumption ±3%
 Fuel Rate ±5%

Ratings are based on SAE J1228/ISO8665 standard conditions of 100 kPa (29.61 in. Hg), 25°C (77°F), and 30% relative humidity. These ratings also apply at ISO3046/1, DIN6271/3, and BS5514 conditions of 100 kPa (29.61 in. Hg), 27°C (81°F), and 60% relative humidity.

Fuel rates are based on fuel oil of 35° API [16°C (60°F)] gravity having an LHV of 42 780 kJ/kg (18,390 Btu/lb) when used at 29°C (85°F) and weighing 838.9 g/L (7.001 lb/U.S. gal).

Additional ratings may be available for specific customer requirements. Consult your Caterpillar representative for additional information.

Performance data is calculated in accordance with tolerances and conditions stated in this specification sheet and is only intended for purposes of comparison with other manufacturers' engines. Actual engine performance may vary according to the particular application of the engine and operating conditions beyond Caterpillar's control.

TMI Reference No.: DM6058-00 (6-19-01)

Materials and specifications are subject to change without notice.

The International System of Units (SI) is used in this publication.

LEHM1237-00 (6-01)

Printed in U.S.A.

Supersedes LEHM7240-01

©2001 Caterpillar
All rights reserved.



Marine Propulsion Engine 3306B

261 kW (350 bhp) 355 mhp @ 2200 rpm

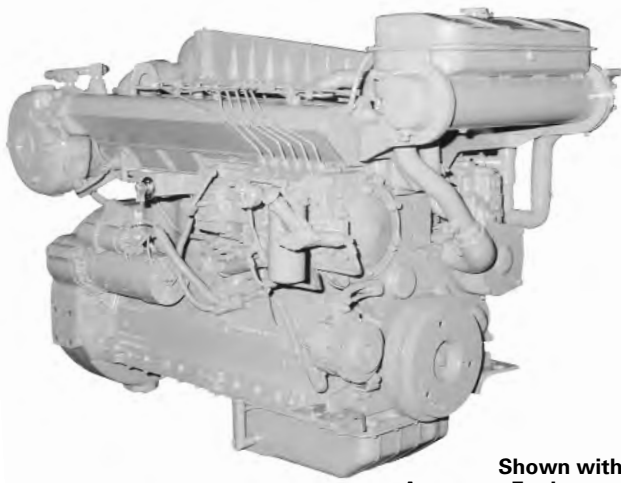

Shown with
Accessory Equipment

STANDARD EQUIPMENT

Air Inlet System

Dry, regular duty air cleaner

Cooling System

Gear driven centrifugal jacket water pump, engine oil cooler, expansion tank, thermostats and housing, transmission oil cooler

Exhaust System

Watercooled manifold and turbocharger; dry elbow and flange, 152 mm (6 in.)

Flywheel and Flywheel Housing

SAE No. 1 (156 teeth)

Fuel System

Fuel priming pump, fuel transfer pump, fuel filter, flexible fuel lines

Instruments

Fuel pressure gauge, service meter, heavy-duty standard SAE rotation tachometer drive

Lube System

Top-mounted crankcase breather, oil filter, LH oil filler and oil level gauge, oil pan

Mounting System

Front support

General

Vibration damper and guard, Caterpillar yellow paint, lifting eyes

SPECIFICATIONS

I-6, 4-Stroke-Cycle-Diesel

Emissions	IMO compliant
Displacement	10.5 L (641 cu. in.)
Bore	121 mm (4.8 in.)
Stroke	152 mm (6.0 in.)
Aspiration	Turbocharged-Aftercooled
Governor	Hydra-mechanical
Engine Weight, Net Dry (approx)	1120.9 kg (2469 lb)
Capacity for Liquids	
Cooling System	18.2 L (4.8 U.S. gal)
Lube Oil System (refill)	27.4 L (7.2 U.S. gal)
Oil Change Interval	250 hr
Caterpillar DEO 10W30 or 15W40	
Rotation (from flywheel end)	Counterclockwise

ACCESSORY EQUIPMENT

Air Cleaner Rain Cap

Air Starting Motor

12V 51 Amp, 24V 35 Amp, 24V 60 Amp Alternator

Auxiliary Drive Pulley

Digital Tachometer

Double Wall Fuel Lines and Drain

Duplex Fuel Filter

Electric Overspeed Shutoff

Electric Starting Motor

Engine-Mounted Instrument Panel

Ether Starting Air

Exhaust Elbow, Pipe, Rain Cap, Flexible Fittings

Front Enclosed Clutch

Fuel Ratio Control

Hydraulic Pump Drive

Magnetic Pickup

Manual Shutoff Lever

Manual Sump Pump

Pilot House Instrument Panel

Primary Fuel Filter/Water Separator

Remote-Mounted Pilot House Controls

Remote Positive Locking Governor Control

RH Oil Level Gauge

Shutoff Solenoid — ETR

Spare Parts Kit

PERFORMANCE CURVES

E Rating — DM6057-00

IMO Compliant

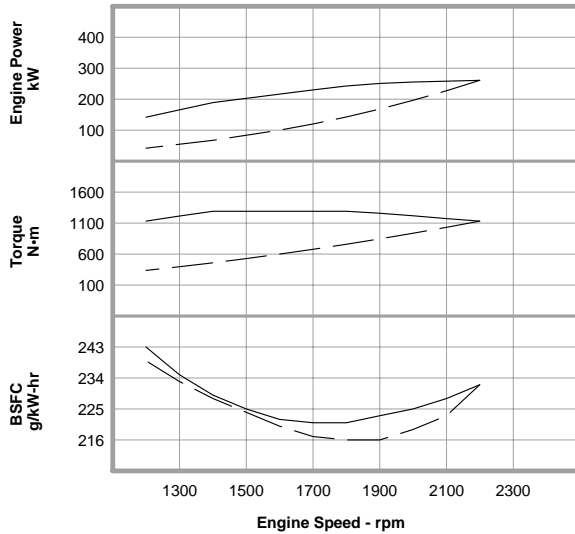

Metric Maximum Power ——— Prop Demand - - - - 261 kW

Performance Data

	Engine Speed rpm	Engine Power kW	Engine Torque N·m	BSFC g/kW-hr	Fuel Rate L/hr
Maximum Power Data	2200	261	1133	232.0	72.1
	2100	258	1173	228.0	70.0
	2000	255	1218	225.0	68.3
	1900	251	1260	223.0	66.5
	1800	243	1291	221.0	64.2
	1700	230	1291	221.0	60.6
	1600	216	1292	222.0	57.3
	1500	203	1292	225.0	54.4
	1400	189	1291	229.0	51.6
	1300	165	1212	235.0	46.2
1200	142	1133	243.0	41.3	
Prop Demand Data	2200	261	1133	232.0	72.1
	2100	227	1032	223.0	60.3
	2000	196	936	219.0	51.1
	1900	168	845	216.0	43.4
	1800	143	758	216.0	36.8
	1700	120	676	217.0	31.2
	1600	100	599	220.0	26.3
	1500	83	527	224.0	22.1
	1400	67	459	228.0	18.3
	1300	54	396	233.0	14.9
1200	42	337	239.0	12.1	

Cubic prop demand curve with 3.0 exponent for displacement hulls only.

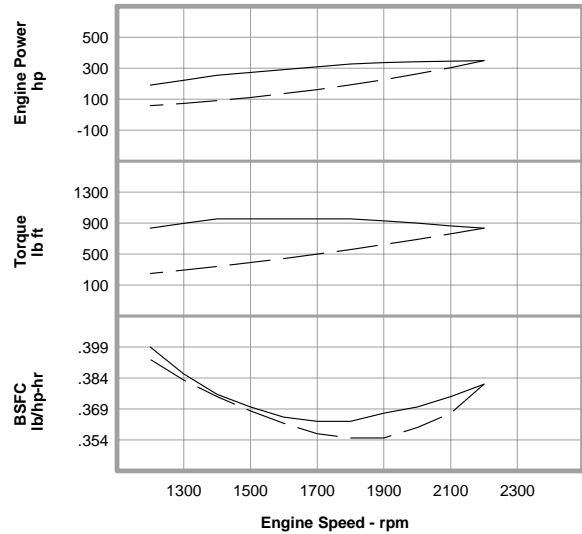

English Maximum Power ——— Prop Demand - - - - 350 hp

Performance Data

	Engine Speed rpm	Engine Power hp	Engine Torque lb ft	BSFC lb/hp-hr	Fuel Rate gph
Maximum Power Data	2200	350	836	.381	19.0
	2100	346	865	.375	18.5
	2000	342	898	.370	18.0
	1900	336	929	.367	17.6
	1800	326	952	.363	17.0
	1700	308	952	.363	16.0
	1600	290	953	.365	15.1
	1500	272	953	.370	14.4
	1400	254	952	.376	13.6
	1300	221	894	.386	12.2
1200	191	836	.399	10.9	
Prop Demand Data	2200	350	836	.381	19.0
	2100	304	761	.367	15.9
	2000	263	690	.360	13.5
	1900	225	623	.355	11.5
	1800	192	559	.355	9.7
	1700	161	499	.357	8.2
	1600	135	442	.362	6.9
	1500	111	389	.368	5.8
	1400	90	339	.375	4.8
	1300	72	292	.383	3.9
1200	57	249	.393	3.2	

Power produced at the flywheel will be within standard tolerances up to 50°C (122°F) combustion air temperature measured at the air cleaner inlet, and fuel temperature up to 52°C (125°F) measured at the fuel filter base. Power rated in accordance with NMMA procedure as crankshaft power. Reduce crankshaft power by 3% for propeller shaft power.

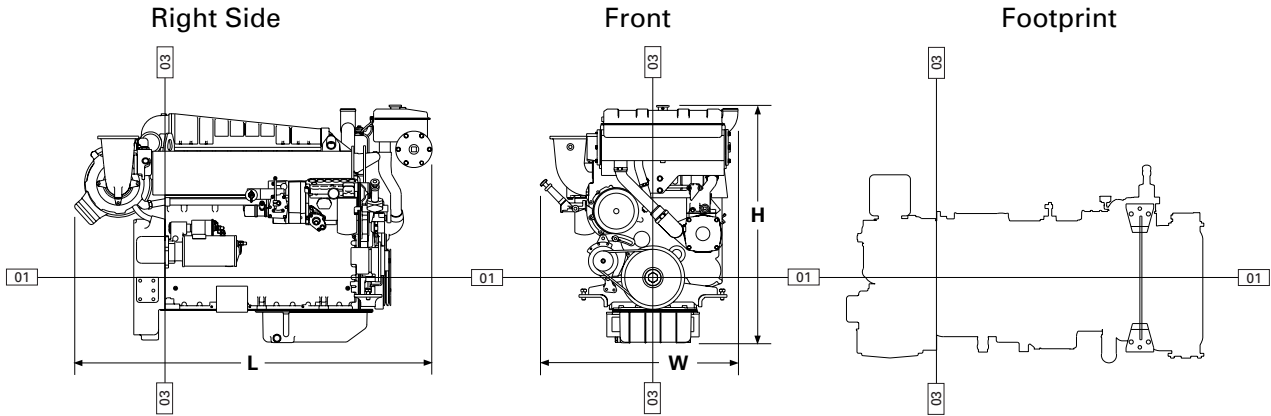

DIMENSIONS*

	mm	in.
Overall Length	1719.2	67.7
Length from rear face of block to front of engine	1285.0	50.6
Length from rear face of block to back of flywheel housing	149.8	5.9
Overall Height	1141.0	44.9
Height from crankshaft centerline to top of engine	827.7	32.6
Height from crankshaft centerline to bottom of oil pan	313.3	12.3
Overall Width	951.1	37.4
Width from crankshaft centerline to port side (left side)	372.0	14.7
Width from crankshaft centerline to starboard side (right side)	542.8	21.4
	Front	
	mm	in.
Customer mounting hole diameter	19.8	0.8
Width from crankshaft centerline to mounting holes	307.8	12.1
Length from rear face of block to mounting holes	935.7	36.8
	1018.3	40.1

*Illustrations and dimensions from drawing:188-1628

RATING DEFINITIONS AND CONDITIONS

E Rating –

Typical Application . . . Planing hull vessels such as pleasure craft, harbor patrol, harbor master, and some fishing and pilot boats.

- Typical Hours Per Year 250 to 1000
- Time at Rated Speed Up to 8%
- Load Factor Up to 30%
- Typical Time at Full Load 1/2 out of 6 hours
- Rated Speed 2200 rpm
- Maximum Cruise Speed 2050 rpm
- Maximum Continuous Cruise Speed 1900 rpm

Engine Performance Parameters

- Power ±3%
- Specific Fuel Consumption ±3%
- Fuel Rate ±5%

Ratings are based on SAE J1228/ISO8665 standard conditions of 100 kPa (29.61 in. Hg), 25°C (77°F), and 30% relative humidity. These ratings also apply at ISO3046/1, DIN6271/3, and BS5514 conditions of 100 kPa (29.61 in. Hg), 27°C (81°F), and 60% relative humidity.

Fuel rates are based on fuel oil of 35° API [16°C (60°F)] gravity having an LHV of 42 780 kJ/kg (18,390 Btu/lb) when used at 29°C (85°F) and weighing 838.9 g/L (7.001 lb/U.S. gal).

Additional ratings may be available for specific customer requirements. Consult your Caterpillar representative for additional information.

Performance data is calculated in accordance with tolerances and conditions stated in this specification sheet and is only intended for purposes of comparison with other manufacturers' engines. Actual engine performance may vary according to the particular application of the engine and operating conditions beyond Caterpillar's control.

TMI Reference No.: DM6057-00 (6-19-01)

Materials and specifications are subject to change without notice.

The International System of Units (SI) is used in this publication.

LEHM1236-00 (6-01)

Printed in U.S.A.

Supersedes LEHM7240-01

©2001 Caterpillar
All rights reserved.



Marine Propulsion 3306B Engine

216 bkW (290 bhp) 294 mhp @ 2200 rpm

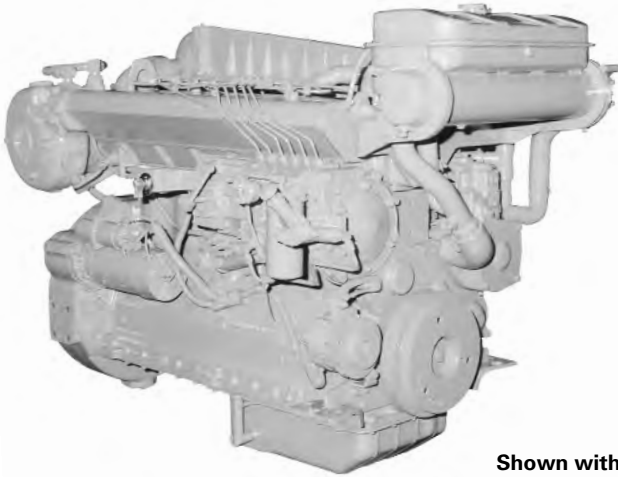

Shown with Accessory Equipment

SPECIFICATIONS

I-6, 4-Stroke-Cycle-Diesel

Emissions	IMO compliant
Displacement	10.5 L (641 cu. in.)
Bore	121 mm (4.8 in.)
Stroke	152 mm (6.0 in.)
Aspiration	Turbocharged-Aftercooled
Governor	Hydra-mechanical
Engine Weight, Net Dry (approx)	1120.9 kg (2469 lb)
Capacity for Liquids	
Cooling System	18.2 L (4.8 U.S. gal)
Lube Oil System (refill)	27.4 L (7.2 U.S. gal)
Oil Change Interval	250 hr
Caterpillar DEO	10W30 or 15W40
Rotation (from flywheel end)	Counterclockwise

STANDARD EQUIPMENT

Air Inlet System

Dry, regular duty air cleaner

Cooling System

Gear driven, self-priming auxiliary sea water pump with rotary rubber impeller; gear driven centrifugal jacket water pump; engine oil cooler; expansion tank; engine mounted heat exchanger with removable tube bundle and replaceable copper-nickel tubes; thermostats and housing

Exhaust System

Watercooled manifold and turbocharger; dry elbow and flange, 152 mm (6 in.)

Flywheel and Flywheel Housing

SAE No. 1 (156 teeth)

Fuel System

Fuel priming pump, fuel transfer pump, fuel filter, flexible fuel lines

Instruments

Fuel pressure gauge, service meter, heavy-duty standard SAE rotation tachometer drive

Lube System

Top-mounted crankcase breather, oil filter, LH oil filler and oil level gauge, oil pan

Mounting System

Front support

General

Vibration damper and guard, Caterpillar yellow paint, lifting eyes

ACCESSORY EQUIPMENT

Air Cleaner Rain Cap

Air Starting Motor

12V 51 Amp, 24V 35 Amp, 24V 60 Amp Alternator

Auxiliary Drive Pulley

Digital Tachometer

Double Wall Fuel Lines and Drain

Duplex Fuel Filter

Electric Overspeed Shutoff

Electric Starting Motor

Engine-Mounted Instrument Panel

Ether Starting Aid

Exhaust Elbow, Pipe, Rain Cap, Flexible Fittings

Front Enclosed Clutch

Fuel Ratio Control

Hydraulic Pump Drive

Magnetic Pickup

Manual Shutoff Lever

Manual Sump Pump

Pilot House Instrument Panel

Primary Fuel Filter/Water Separator

Remote-Mounted Pilot House Controls

Remote Positive Locking Governor Control

RH Oil Level Gauge

Shutoff Solenoid — ETR

Spare Parts Kit

PERFORMANCE CURVES

C Rating — DM6054-00

IMO Compliant

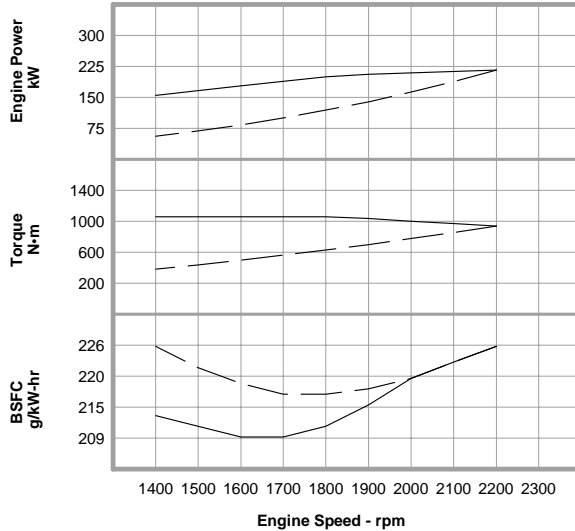

Metric **Maximum Power** **216 kW**
Prop Demand

Performance Data

	Engine Speed rpm	Engine Power kW	Engine Torque N·m	BSFC g/kW-hr	Fuel Rate L/hr
Maximum Power Data	2200	216	938	226.0	58.2
	2100	213	969	223.0	56.7
	2000	209	998	220.0	54.7
	1900	206	1035	215.0	52.9
	1800	200	1059	211.0	50.3
	1700	189	1059	209.0	47.0
	1600	178	1059	209.0	44.2
	1500	166	1059	211.0	41.8
Prop Demand Data	1400	155	1059	213.0	39.5
	2200	216	939	226.0	58.3
	2100	188	855	223.0	50.0
	2000	163	776	220.0	42.6
	1900	139	700	218.0	36.2
	1800	119	628	217.0	30.6
	1700	100	561	217.0	25.8
	1600	83	497	219.0	21.7
1500	69	436	222.0	18.1	
1400	56	380	226.0	15.0	

Cubic prop demand curve with 3.0 exponent for displacement hulls only.

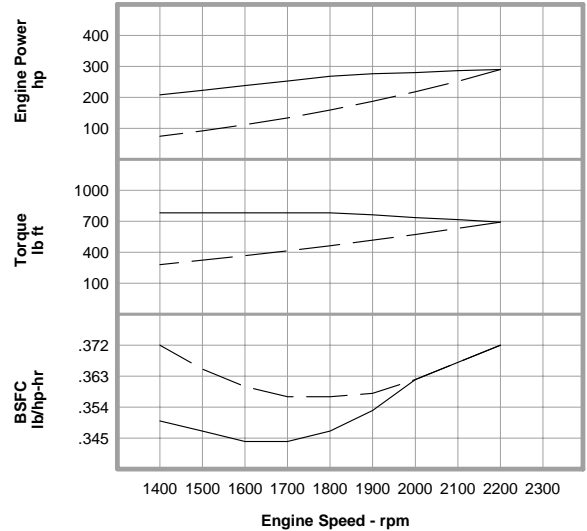

English **Maximum Power** **290 hp**
Prop Demand

Performance Data

	Engine Speed rpm	Engine Power hp	Engine Torque lb ft	BSFC lb/hp-hr	Fuel Rate gph
Maximum Power Data	2200	290	692	.372	15.4
	2100	286	715	.367	15.0
	2000	280	736	.362	14.5
	1900	276	763	.353	14.0
	1800	268	781	.347	13.3
	1700	253	781	.344	12.4
	1600	238	781	.344	11.7
	1500	223	781	.347	11.0
Prop Demand Data	1400	208	781	.350	10.4
	2200	290	693	.372	15.4
	2100	252	631	.367	13.2
	2000	218	572	.362	11.3
	1900	187	516	.358	9.6
	1800	159	463	.357	8.1
	1700	134	414	.357	6.8
	1600	112	367	.360	5.7
1500	92	322	.365	4.8	
1400	75	280	.372	4.0	

Power produced at the flywheel will be within standard tolerances up to 50°C (122°F) combustion air temperature measured at the air cleaner inlet, and fuel temperature up to 52°C (125°F) measured at the fuel filter base. Power rated in accordance with NMMA procedure as crankshaft power. Reduce crankshaft power by 3% for propeller shaft power.

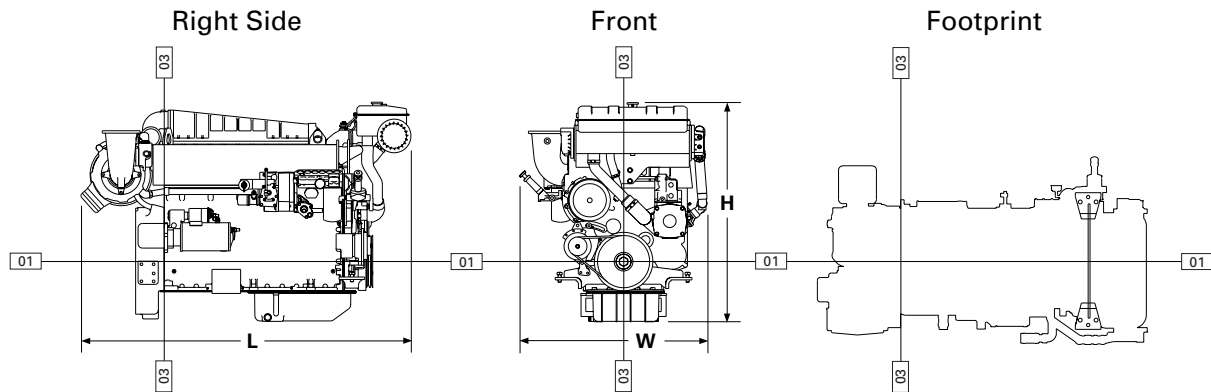

DIMENSIONS*

	mm	in.
Overall Length	1719.2	67.7
Length from rear face of block to front of engine	1285.0	50.6
Length from rear face of block to back of flywheel housing	149.8	5.9
Overall Height	1141.0	44.9
Height from crankshaft centerline to top of engine	827.7	32.6
Height from crankshaft centerline to bottom of oil pan	313.3	12.3
Overall Width	977.6	38.5
Width from crankshaft centerline to port side (left side)	434.8	17.1
Width from crankshaft centerline to starboard side (right side)	542.8	21.4
	Front	
	mm	in.
Customer mounting hole diameter	19.8	0.8
Width from crankshaft centerline to mounting holes	307.8	12.1
Length from rear face of block to mounting holes	935.7	36.8
	1018.3	40.1

*Illustrations and dimensions from drawing: 118-7821

RATING DEFINITIONS AND CONDITIONS

C Rating –

Typical Application . . . Vessels such as ferries, harbor tugs, fishing boats moving at higher speeds out and back (e.g. lobster, crayfish, and tuna), offshore service boats, and also displacement hull yachts and short trip coastal freighters where engine load and speed are cyclical.

Typical Hours Per Year	2000 to 4000
Time at Rated Speed	Up to 50%
Load Factor	20 to 80%
Typical Time at Full Load	6 out of 12 hours
Rated Speed	2200 rpm
Maximum Cruise Speed	2100 rpm
Maximum Continuous Cruise Speed	2000 rpm

Engine Performance Parameters

Power	±3%
Specific Fuel Consumption	±3%
Fuel Rate	±5%

Ratings are based on SAE J1228/ISO8665 standard conditions of 100 kPa (29.61 in. Hg), 25°C (77°F), and 30% relative humidity. These ratings also apply at ISO3046/1, DIN6271/3, and BS5514 conditions of 100 kPa (29.61 in. Hg), 27°C (81°F), and 60% relative humidity.

Fuel rates are based on fuel oil of 35° API [16°C (60°F)] gravity having an LHV of 42 780 kJ/kg (18,390 Btu/lb) when used at 29°C (85°F) and weighing 838.9 g/L (7.001 lb/U.S. gal).

Additional ratings may be available for specific customer requirements. Consult your Caterpillar representative for additional information.

Performance data is calculated in accordance with tolerances and conditions stated in this specification sheet and is only intended for purposes of comparison with other manufacturers' engines. Actual engine performance may vary according to the particular application of the engine and operating conditions beyond Caterpillar's control.

TMI Reference No.: DM6054-00 (6-19-01)

Materials and specifications are subject to change without notice.

The International System of Units (SI) is used in this publication.

LEHM1235-00 (6-01)

Supersedes LEHM7240-01

Printed in U.S.A.

©2001 Caterpillar
All rights reserved.



Marine Propulsion Engine 3306B

250 bkW (335 bhp) 340 mhp @ 2200 rpm

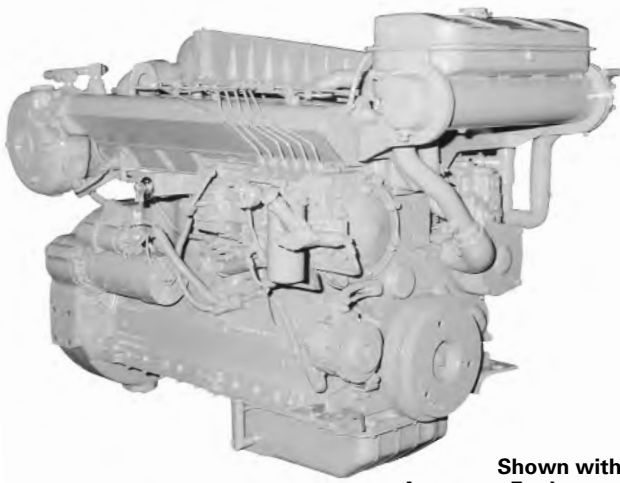

Shown with Accessory Equipment

STANDARD EQUIPMENT

Air Inlet System

Dry, regular duty air cleaner

Cooling System

Gear driven, self-priming auxiliary sea water pump with rotary rubber impeller; gear driven centrifugal jacket water pump; engine oil cooler; expansion tank; engine mounted heat exchanger with removable tube bundle and replaceable copper-nickel tubes; thermostats and housing

Exhaust System

Watercooled manifold and turbocharger; dry elbow and flange, 152 mm (6 in.)

Flywheel and Flywheel Housing

SAE No. 1 (156 teeth)

Fuel System

Fuel priming pump, fuel transfer pump, fuel filter, flexible fuel lines

Instruments

Fuel pressure gauge, service meter, heavy-duty standard SAE rotation tachometer drive

Lube System

Top-mounted crankcase breather, oil filter, LH oil filler and oil level gauge, oil pan

Mounting System

Front support

General

Vibration damper and guard, Caterpillar yellow paint, lifting eyes

SPECIFICATIONS

I-6, 4-Stroke-Cycle-Diesel

Emissions	IMO compliant
Displacement	10.5 L (641 cu. in.)
Bore	121 mm (4.8 in.)
Stroke	152 mm (6.0 in.)
Aspiration	Turbocharged-Aftercooled
Governor	Hydra-mechanical
Engine Weight, Net Dry (approx)	1120.9 kg (2469 lb)
Capacity for Liquids	
Cooling System	18.2 L (4.8 U.S. gal)
Lube Oil System (refill)	27.4 L (7.2 U.S. gal)
Oil Change Interval	250 hr
Caterpillar DEO 10W30 or 15W40	
Rotation (from flywheel end)	Counterclockwise

ACCESSORY EQUIPMENT

Air Cleaner Rain Cap

Air Starting Motor

12V 51 Amp, 24V 35 Amp, 24V 60 Amp Alternator

Auxiliary Drive Pulley

Digital Tachometer

Double Wall Fuel Lines and Drain

Duplex Fuel Filter

Electric Overspeed Shutoff

Electric Starting Motor

Engine-Mounted Instrument Panel

Ether Starting Aid

Exhaust Elbow, Pipe, Rain Cap, Flexible Fittings

Front Enclosed Clutch

Fuel Ratio Control

Hydraulic Pump Drive

Magnetic Pickup

Manual Shutoff Lever

Manual Sump Pump

Pilot House Instrument Panel

Primary Fuel Filter/Water Separator

Remote-Mounted Pilot House Controls

Remote Positive Locking Governor Control

RH Oil Level Gauge

Shutoff Solenoid — ETR

Spare Parts Kit

PERFORMANCE CURVES

D Rating — DM6053-00

IMO Compliant

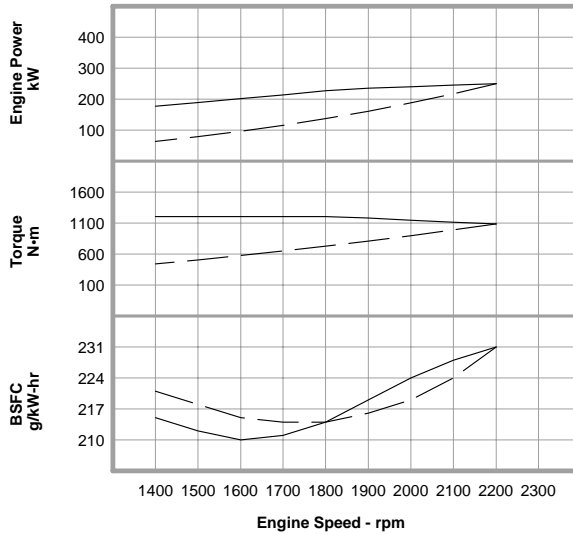

Metric **Maximum Power** **250 kW**
Prop Demand

Performance Data

	Engine Speed rpm	Engine Power kW	Engine Torque N·m	BSFC g/kW-hr	Fuel Rate L/hr
Maximum Power Data	2200	250	1085	231.0	68.7
	2100	245	1114	228.0	66.6
	2000	240	1145	224.0	64.1
	1900	235	1181	219.0	61.3
	1800	227	1204	214.0	57.8
	1700	214	1204	211.0	53.8
	1600	202	1204	210.0	50.5
	1500	189	1204	212.0	47.7
1400	177	1205	215.0	45.2	
Prop Demand Data	2200	250	1085	231.0	68.7
	2100	217	989	224.0	58.0
	2000	188	897	219.0	49.0
	1900	161	809	216.0	41.4
	1800	137	726	214.0	34.9
	1700	115	648	214.0	29.4
	1600	96	574	215.0	24.7
	1500	79	504	218.0	20.6
1400	64	439	221.0	17.0	

Cubic prop demand curve with 3.0 exponent for displacement hulls only.

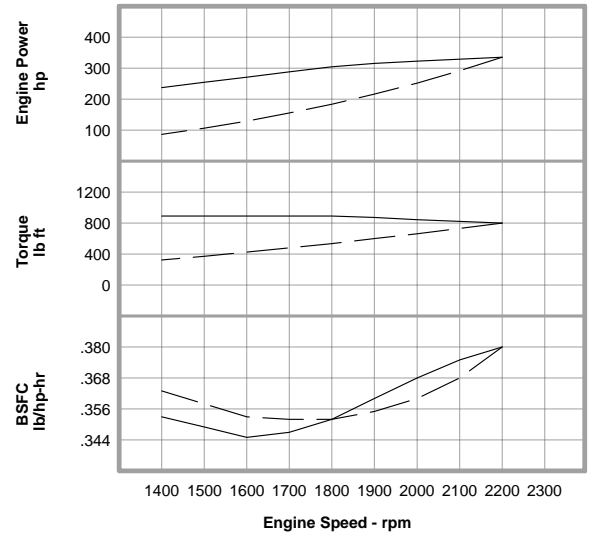

English **Maximum Power** **335 hp**
Prop Demand

Performance Data

	Engine Speed rpm	Engine Power hp	Engine Torque lb ft	BSFC lb/hp-hr	Fuel Rate gph
Maximum Power Data	2200	335	800	.380	18.1
	2100	329	822	.375	17.6
	2000	322	844	.368	16.9
	1900	315	871	.360	16.2
	1800	304	888	.352	15.3
	1700	288	888	.347	14.2
	1600	271	888	.345	13.3
	1500	254	888	.349	12.6
1400	237	889	.353	11.9	
Prop Demand Data	2200	335	800	.380	18.1
	2100	292	729	.368	15.3
	2000	252	662	.360	12.9
	1900	216	597	.355	10.9
	1800	184	535	.352	9.2
	1700	155	478	.352	7.8
	1600	129	423	.353	6.5
	1500	106	372	.358	5.4
1400	86	324	.363	4.5	

Power produced at the flywheel will be within standard tolerances up to 50°C (122°F) combustion air temperature measured at the air cleaner inlet, and fuel temperature up to 52°C (125°F) measured at the fuel filter base. Power rated in accordance with NMMA procedure as crankshaft power. Reduce crankshaft power by 3% for propeller shaft power.

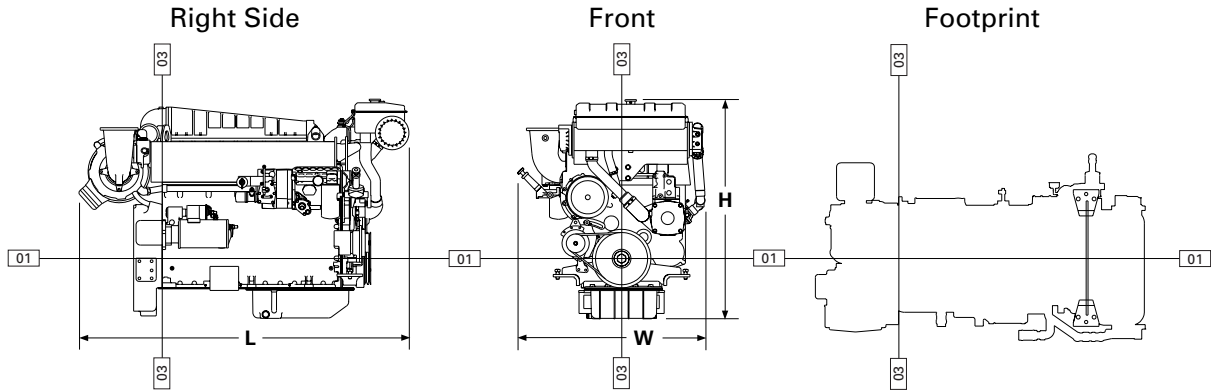

DIMENSIONS*

	mm	in.
Overall Length	1719.2	67.7
Length from rear face of block to front of engine	1285.0	50.6
Length from rear face of block to back of flywheel housing	149.8	5.9
Overall Height	1141.0	44.9
Height from crankshaft centerline to top of engine	827.7	32.6
Height from crankshaft centerline to bottom of oil pan	313.3	12.3
Overall Width	977.6	38.5
Width from crankshaft centerline to port side (left side)	434.8	17.1
Width from crankshaft centerline to starboard side (right side)	542.8	21.4
	Front	
	mm	in.
Customer mounting hole diameter	19.8	0.8
Width from crankshaft centerline to mounting holes	307.8	12.1
Length from rear face of block to mounting holes	935.7	36.8
	1018.3	40.1

*Illustrations and dimensions from drawing: 118-7821

RATING DEFINITIONS AND CONDITIONS

D Rating –

Typical Application . . . Planing hull vessels such as offshore patrol boats, customs, police, and some fire and fishing boats. Also used for bow and stern thrusters.

Typical Hours Per Year 1000 to 3000
 Time at Rated Speed Up to 16%
 Load Factor Up to 50%
 Typical Time at Full Load 2 out of 12 hours

Rated Speed 2200 rpm
 Maximum Cruise Speed 2050 rpm
 Maximum Continuous Cruise Speed 1900 rpm

Engine Performance Parameters

Power ±3%
 Specific Fuel Consumption ±3%
 Fuel Rate ±5%

Ratings are based on SAE J1228/ISO8665 standard conditions of 100 kPa (29.61 in. Hg), 25°C (77°F), and 30% relative humidity. These ratings also apply at ISO3046/1, DIN6271/3, and BS5514 conditions of 100 kPa (29.61 in. Hg), 27°C (81°F), and 60% relative humidity.

Fuel rates are based on fuel oil of 35° API [16°C (60°F)] gravity having an LHV of 42 780 kJ/kg (18,390 Btu/lb) when used at 29°C (85°F) and weighing 838.9 g/L (7.001 lb/U.S. gal).

Additional ratings may be available for specific customer requirements. Consult your Caterpillar representative for additional information.

Performance data is calculated in accordance with tolerances and conditions stated in this specification sheet and is only intended for purposes of comparison with other manufacturers' engines. Actual engine performance may vary according to the particular application of the engine and operating conditions beyond Caterpillar's control.

TMI Reference No.: DM6053-00 (6-19-01)

Materials and specifications are subject to change without notice.

The International System of Units (SI) is used in this publication.

LEHM1234-00 (6-01)

Supersedes LEHM7240-01

Printed in U.S.A.

©2001 Caterpillar
All rights reserved.



Marine Propulsion 3306B Engine

265 kW (355 bhp) 360 mhp @ 2200 rpm

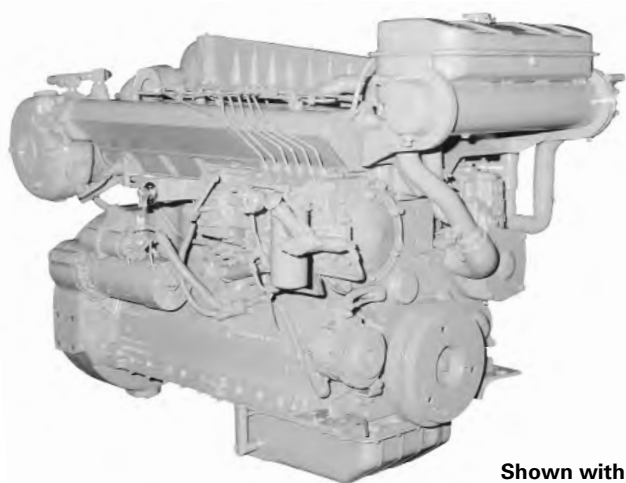

Shown with Accessory Equipment

STANDARD EQUIPMENT

Air Inlet System

Dry, regular duty air cleaner

Cooling System

Gear driven, self-priming auxiliary sea water pump with rotary rubber impeller; gear driven centrifugal jacket water pump; engine oil cooler; expansion tank; engine mounted heat exchanger with removable tube bundle and replaceable copper-nickel tubes; thermostats and housing

Exhaust System

Watercooled manifold and turbocharger; dry elbow and flange, 152 mm (6 in.)

Flywheel and Flywheel Housing

SAE No. 1 (156 teeth)

Fuel System

Fuel priming pump, fuel transfer pump, fuel filter, flexible fuel lines

Instruments

Fuel pressure gauge, service meter, heavy-duty standard SAE rotation tachometer drive

Lube System

Top-mounted crankcase breather, oil filter, LH oil filler and oil level gauge, oil pan

Mounting System

Front support

General

Vibration damper and guard, Caterpillar yellow paint, lifting eyes

SPECIFICATIONS

I-6, 4-Stroke-Cycle-Diesel

Emissions	IMO compliant
Displacement	10.5 L (641 cu. in.)
Bore	121 mm (4.8 in.)
Stroke	152 mm (6.0 in.)
Aspiration	Turbocharged-Aftercooled
Governor	Hydra-mechanical
Engine Weight, Net Dry (approx)	1120.9 kg (2469 lb)
Capacity for Liquids	
Cooling System	18.2 L (4.8 U.S. gal)
Lube Oil System (refill)	27.4 L (7.2 U.S. gal)
Oil Change Interval	250 hr
Caterpillar DEO 10W30 or 15W40	
Rotation (from flywheel end)	Counterclockwise

ACCESSORY EQUIPMENT

- Air Cleaner Rain Cap
- Air Starting Motor
- 12V 51 Amp, 24V 35 Amp, 24V 60 Amp Alternator
- Auxiliary Drive Pulley
- Digital Tachometer
- Double Wall Fuel Lines and Drain
- Duplex Fuel Filter
- Electric Overspeed Shutoff
- Electric Starting Motor
- Engine-Mounted Instrument Panel
- Ether Starting Aid
- Exhaust Elbow, Pipe, Rain Cap, Flexible Fittings
- Front Enclosed Clutch
- Fuel Ratio Control
- Hydraulic Pump Drive
- Magnetic Pickup
- Manual Shutoff Lever
- Manual Sump Pump
- Pilot House Instrument Panel
- Primary Fuel Filter/Water Separator
- Remote-Mounted Pilot House Controls
- Remote Positive Locking Governor Control
- RH Oil Level Gauge
- Shutoff Solenoid — ETR
- Spare Parts Kit

PERFORMANCE CURVES

E Rating — DM6052-00

IMO Compliant

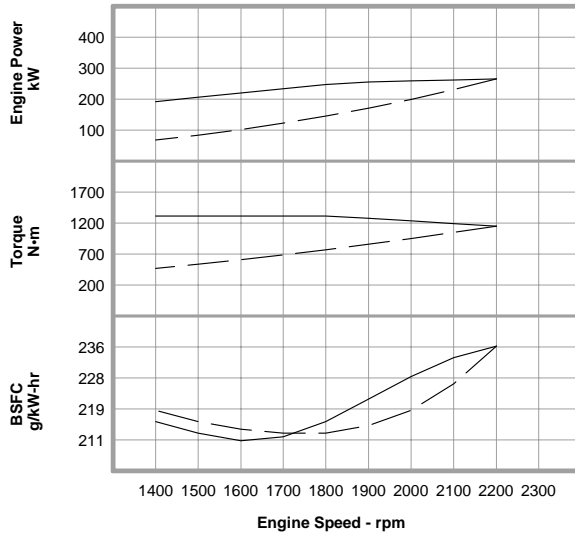

Metric **Maximum Power** ——— **265 kW**
Prop Demand - - - - -

Performance Data

	Engine Speed rpm	Engine Power kW	Engine Torque N·m	BSFC g/kW-hr	Fuel Rate L/hr
Maximum Power Data	2200	265	1150	236.0	74.4
	2100	262	1191	233.0	72.7
	2000	259	1237	228.0	70.4
	1900	255	1279	222.0	67.4
	1800	247	1311	216.0	63.7
	1700	233	1311	212.0	59.1
	1600	220	1311	211.0	55.4
	1500	206	1311	213.0	52.3
Prop Demand Data	1400	192	1311	216.0	49.5
	2200	265	1150	236.0	74.4
	2100	231	1048	226.0	62.0
	2000	199	951	219.0	52.0
	1900	171	858	215.0	43.8
	1800	145	770	213.0	36.9
	1700	122	687	213.0	31.0
	1600	102	608	214.0	26.0
1500	84	535	216.0	21.7	
1400	68	466	219.0	17.9	

Cubic prop demand curve with 3.0 exponent for displacement hulls only.

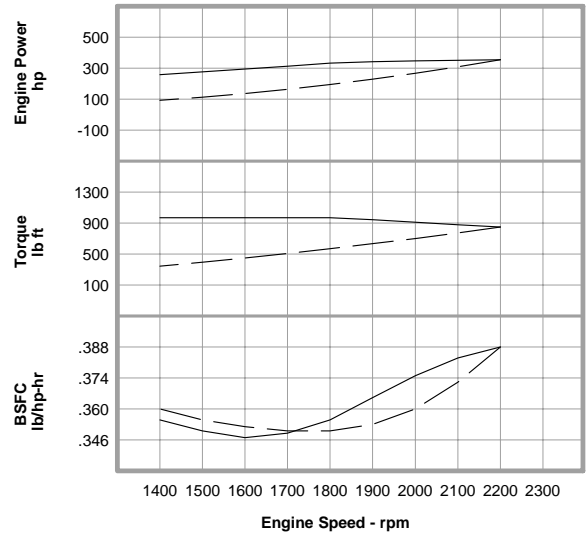

English **Maximum Power** ——— **355 hp**
Prop Demand - - - - -

Performance Data

	Engine Speed rpm	Engine Power hp	Engine Torque lb ft	BSFC lb/hp-hr	Fuel Rate gph
Maximum Power Data	2200	355	848	.388	19.7
	2100	351	878	.383	19.2
	2000	347	912	.375	18.6
	1900	341	943	.365	17.8
	1800	332	967	.355	16.8
	1700	313	967	.349	15.6
	1600	295	967	.347	14.6
	1500	276	967	.350	13.8
Prop Demand Data	1400	258	967	.355	13.1
	2200	355	848	.388	19.7
	2100	309	773	.372	16.4
	2000	267	701	.360	13.7
	1900	229	633	.353	11.6
	1800	195	568	.350	9.7
	1700	164	507	.350	8.2
	1600	137	448	.352	6.9
1500	113	395	.355	5.7	
1400	92	344	.360	4.7	

Power produced at the flywheel will be within standard tolerances up to 50°C (122°F) combustion air temperature measured at the air cleaner inlet, and fuel temperature up to 52°C (125°F) measured at the fuel filter base. Power rated in accordance with NMMA procedure as crankshaft power. Reduce crankshaft power by 3% for propeller shaft power.

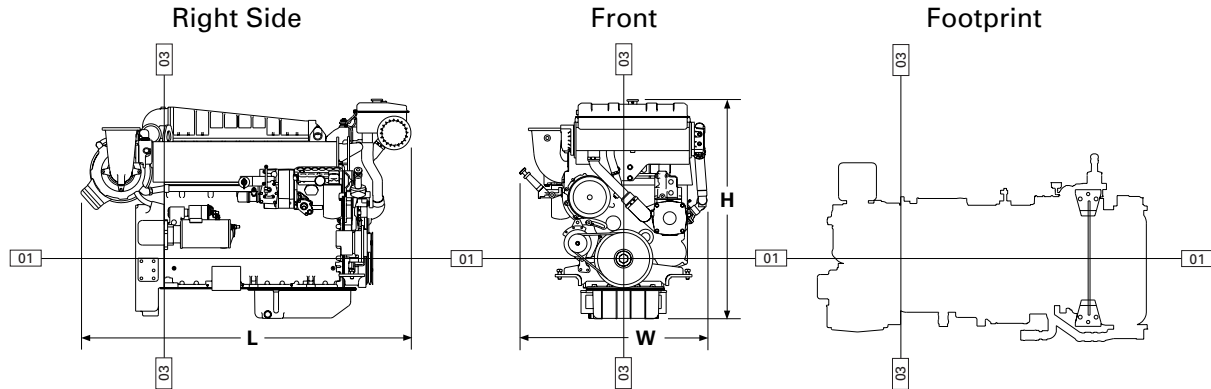

DIMENSIONS*

	mm	in.
Overall Length	1719.2	67.7
Length from rear face of block to front of engine	1285.0	50.6
Length from rear face of block to back of flywheel housing	149.8	5.9
Overall Height	1141.0	44.9
Height from crankshaft centerline to top of engine	827.7	32.6
Height from crankshaft centerline to bottom of oil pan	313.3	12.3
Overall Width	977.6	38.5
Width from crankshaft centerline to port side (left side)	434.8	17.1
Width from crankshaft centerline to starboard side (right side)	542.8	21.4
	Front	
	mm	in.
Customer mounting hole diameter	19.8	0.8
Width from crankshaft centerline to mounting holes	307.8	12.1
Length from rear face of block to mounting holes	935.7	36.8
	1018.3	40.1

*Illustrations and dimensions from drawing: 118-7821

RATING DEFINITIONS AND CONDITIONS

E Rating –

Typical Application . . . Planing hull vessels such as pleasure craft, harbor patrol, harbor master, and some fishing and pilot boats.

- Typical Hours Per Year 250 to 1000
- Time at Rated Speed Up to 8%
- Load Factor Up to 30%
- Typical Time at Full Load 1/2 out of 6 hours
- Rated Speed 2200 rpm
- Maximum Cruise Speed 2050 rpm
- Maximum Continuous Cruise Speed 1900 rpm

Engine Performance Parameters

- Power ±3%
- Specific Fuel Consumption ±3%
- Fuel Rate ±5%

Ratings are based on SAE J1228/ISO8665 standard conditions of 100 kPa (29.61 in. Hg), 25°C (77°F), and 30% relative humidity. These ratings also apply at ISO3046/1, DIN6271/3, and BS5514 conditions of 100 kPa (29.61 in. Hg), 27°C (81°F), and 60% relative humidity.

Fuel rates are based on fuel oil of 35° API [16°C (60°F)] gravity having an LHV of 42 780 kJ/kg (18,390 Btu/lb) when used at 29°C (85°F) and weighing 838.9 g/L (7.001 lb/U.S. gal).

Additional ratings may be available for specific customer requirements. Consult your Caterpillar representative for additional information.



3306B MARINE PROPULSION — 265 bkW (355 bhp)

Performance data is calculated in accordance with tolerances and conditions stated in this specification sheet and is only intended for purposes of comparison with other manufacturers' engines. Actual engine performance may vary according to the particular application of the engine and operating conditions beyond Caterpillar's control.

TMI Reference No.: DM6052-00 (6-19-01)

Materials and specifications are subject to change without notice.

The International System of Units (SI) is used in this publication.

LEHM1233-00 (6-01)

Printed in U.S.A.

Supersedes LEHM7240-01

©2001 Caterpillar
All rights reserved.